



CAPACITIVE LEVEL METERS CLM-40

TABLE OF CONTENTS

1. Measuring principle	3
2. Areas of application	3
3. Variants of sensors	4
4. Dimensional drawings	4
5. Installation and putting into operation	4
6. Installation	5
7. Electrical connection	5
8. Setting	6
9. Use, manipulation and maintenance	7
10. Order code	7
11. Correct specification examples	7
12. Accessories	8
13. Safety, protections and compatibility	8
14. Marking of labels	8
15. Specification	9

USED SYMBOLS

To ensure maximum safety of control processes, we have defined the following safety instructions and information. Each instruction is labeled with the appropriate pictogram.



Alert, warning, danger

This symbol informs you about particularly important instructions for installation and operation of equipment or dangerous situations that may occur during the installation and operation. Not observing these instructions may cause disturbance, damage or destruction of equipment or may cause injury



Information

This symbol indicates particularly important characteristics of the device.



Note

This symbol indicates helpful additional information.

all types

Valid for:

In the border are the types CLM, for which is intended the chapter.

SAFETY



All operations described in this instruction manual have to be carried out only by trained personnel or an accredited person. Warranty and post warranty service must be exclusively carried out by the manufacturer.

Improper use, installation or set-up of the level meter can result in crashes in the application (overfilling of the tank or damage of system components).

The manufacturer is not responsible for improper use, losses of work caused by either direct or indirect damage, and for expenses incurred during installation or use of the level meter.

1. MEASURING PRINCIPLE

Capacitive level meter CLM® is intended for continuous measurement of the level of fuel (diesel). It consists of a measuring electrode and the electronics housing to which is firmly attached the cable. The electronic part converts the capacity to the current or voltage signal. For accurate measurements independent on the tank shape is the rod electrode placed inside the reference tube. Setting is done by touching the magnetic pen. The level meter has no neither mechanical moving parts and so its installation is very simple. The production of its electrodes is possible in any length in the range from 100 to 1000 mm, so that the level meter can go through entire height of the tank. Mounting of the tank level meter is done by using 5-hole flange (SAE).

2. AREAS OF APPLICATION

Accurate level measurement in diesel tanks of trucks, construction and agricultural machinery, locomotives etc. After consultation with the manufacturer can be used for measuring and other non-conductive liquids (eg .: biodiesel, oil, etc.). CLMs are resistant to any changes in the atmosphere above the surface (vacuum, pressure, vapours, dust).

3. VARIANTS OF SENSORS

CLM-40N-40 **Uncoated rod electrode and reference tube**, setting is done by touching the magnetic pen for the measured medium, possibility of shortening electrodes to the desired length.
Electrode length from 0.1 m to 1 m.

4. DIMENSIONAL DRAWINGS

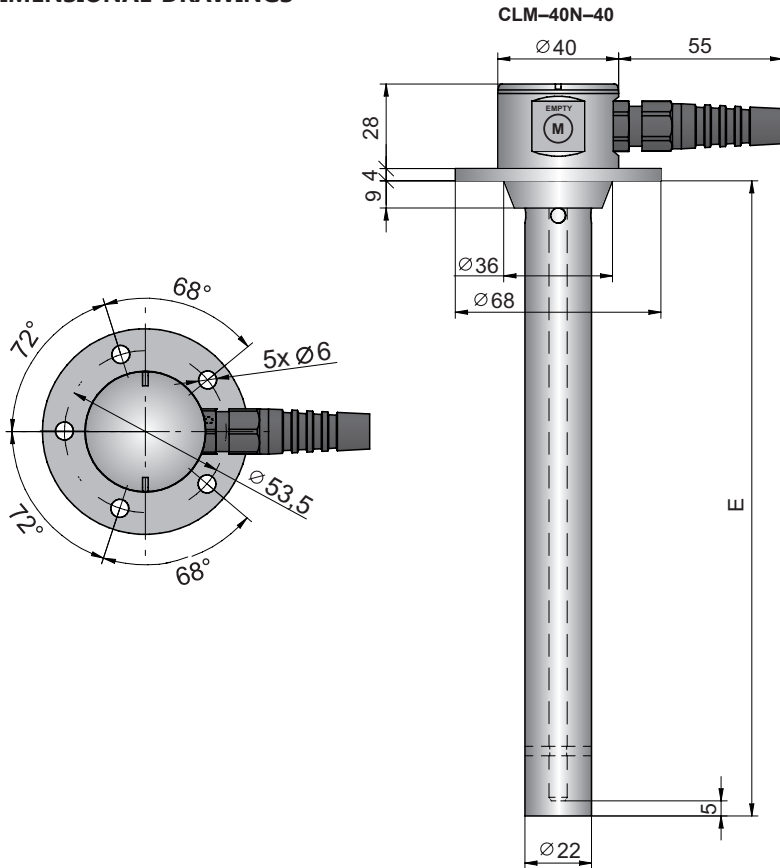

5. INSTALLATION AND PUTTING INTO OPERATION

Please follow next 3 steps:

- **INSTALLATION**
- **ELECTRICAL CONNECTION**
- **SETTING**

6. INSTALLATION

- Mounting of the tank level meter is done by using 5-hole flange (SAE). Distance from the wall may be arbitrary and distance from the bottom is recommended min. 10 mm.
- Under the flange of the level, it is necessary to put in the rubber gasket resistant to petroleum products (see. Accessories).
- The level meter can be also used for similar applications in stationary tanks, containers, etc.

7. ELECTRICAL CONNECTION

The level meter is designed to be connected to supply unit or to controller through two or three-wire cable with. Connection diagram and inner view of the connector as shown in picture. Always disconnect the power supply before connecting the level meter! You can use car battery (24 V) or power supply (9 ... 30 V DC).

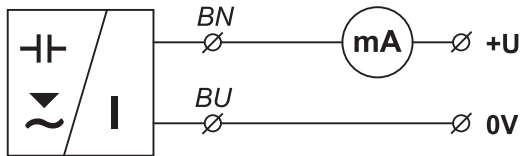

Fig.1: Scheme of electrical connection



Electrical connection can only be made when de-energized!



The voltage source should be preferably realized as a stabilized power supply unit with safe voltage from 18 to 36 V DC, which can be a part of the evaluation or display device.

In case of strong ambient electromagnetic interference, paralleling of conductors with power distribution, or for the distribution to distance over 30 m, we recommend using shielded cable.

8. SETTING

The device shall be set up by applying the magnetic pen onto sensitive spots.

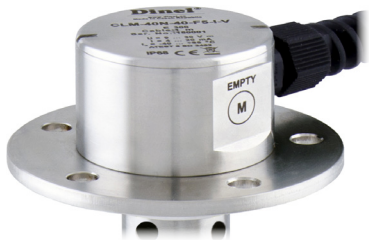

Basic mode

Setting of lower limit 4 mA

1. Drain the tank to the lower measured level.
2. Set the level meter output to the value of 4 mA by applying the magnetic pen to the sensitive spot "EMPTY" for at least 2 s. Hold the magnetic pen on the sensitive spot for at least additional 3 s to confirm the set value and store it in the internal memory of the level meter.
3. Any other setting is possible 2 s after the magnetic pen is removed from the sensitive spot.

Setting of upper limit 20 mA

1. Fill the tank up to the upper measured level.
2. Set the level meter output to the value of 20 mA by applying the magnetic pen to the sensitive spot "FULL" for at least 2 s. Hold the magnetic pen on the sensitive spot for at least additional 3 s to confirm the set value and store it in the internal memory of the level meter.
3. Any other setting is possible 2 s after the magnetic pen is removed from the sensitive spot.

Inverse mode

In the inverse mode, set the lower limit of 4 mA when the tank is filled up to the upper measured surface level and the upper limit of 20 mA when the tank is drained to the lower measured surface level.

9. USE, MANIPULATION AND MAINTENANCE

The level meter does not require any personnel for its operation. Follow-up displaying device is used to inform the technological entity operating personnel on the measured substance level height during the operation.

MAINTAINCE OF LEVEL METER

Maintenance of this equipment consists in verification of integrity of the level meter and of the supply cable. Depending on the character of the substance measured, we recommend to verify at least once per year the clarity of the ultrasound transducer emitting field and to clean it, respectively. In case any visible defects are discovered, the manufacturer or reseller of this equipment must be contacted immediately.



It is forbidden to perform any modifications or interventions into the CLM-40 level meter without manufacturer's approval. Potential repairs must be carried out by the manufacturer or by a manufacturer authorized service organization only.

Installation, commissioning, operation and maintenance of the CLM-40 level meter has to be carried out in accordance with this instruction manual; the provisions of regulations in force regarding the installation of electrical equipment have to be adhered to.

10. ORDER CODE

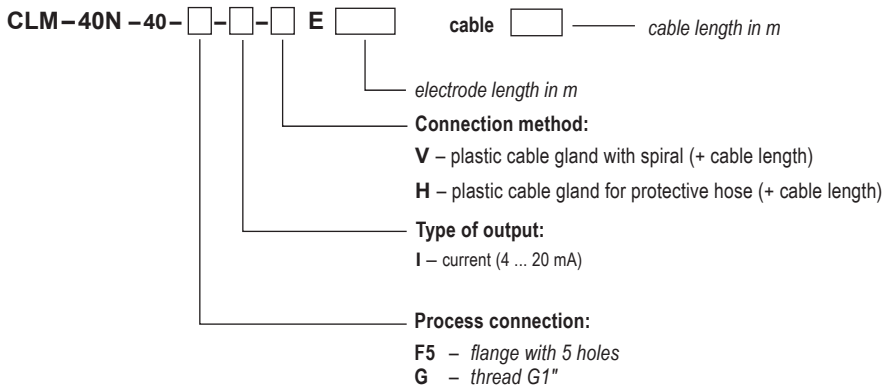

11. CORRECT SPECIFICATION EXAMPLES

CLM-40N-40-F5-I-V E1000

(N) performance to normal area; (40) rod electrode with reference tube; (F) flange with 5 holes; (I) current output (4 ... 20 mA); (V) cable gland; (E1000) length of electrode 1000 mm

CLM-40N-40-G-I-H E800

(N) performance to normal area; (40) rod electrode with reference tube; (G) thread G1"; (I) current output (4 ... 20 mA); (H) cable gland for protective hose; (E800) length of electrode 800 mm

12. ACCESSORIES

Optional – for extra charge

- Extra cable (over the standard length 2 m)
- Rubber seal CLM-40 5 otv NBR (for flange with 5 holes)

13. SAFETY, PROTECTIONS AND COMPATIBILITY

Level meter CLM-40 is equipped with protection against electric shock on electrode, reverse polarity, output current overload, short circuit and short time over voltages.

Electromagnetic compatibility is provided by conformity with standards: EN 55022/B, EN 61326-1, EN 61000-4-2, EN 61000-4-3, EN 61000-4-4, EN 61000-4-5, EN 61000-4-6.

14. MARKING OF LABELS

Level meters label data **CLM-40N-40-_-_-I-_-**:



Symbol of producer: logo Dinel[®]

web address: www.dinel.cz

Country of origin: Made in Czech Republic

Type of level meter: CLM-40N-40-_-_-I-_-

include length of electrode: E v mm

Length of cable: Cable 1 m

Serial number: Ser. No.: _____ -

(from the left: production year, serial production number)

Supply voltage: U = 9 ÷ 30 V DC

Output current range: I = 4 ÷ 20 mA

Ambient temperature range: t_a = -40 ... +85 °C

Protection class: IP 68

Compliance mark: 

Electro-waste take-back system mark: 

15. SPECIFICATION

TECHNICAL SPECIFICATION		
Supply voltage		9 ... 30 V DC
Current output		4 ... 20 mA
Load resistance		$R \leq (U - 9) / 0,02$ [Ω ; V]
Nonlinearity		max. 1 %
Temperature error		max. 0,05% / K
Voltage error for current and voltage output		max. 0,3 μ A/V
Internal resistance / Electric strength (Electrode – Housing)		1 M Ω / 200 V AC
Coupling capacity / Electric strength (Housing – Supply leads)		91 nF / 500 V AC
Coupling capacity / Electric strength (Electrode – Supply leads)		47 nF / 500 V AC
Protection class		IP68
Ambient temperature range		- 40 ... +85 °C
Cable		PU 2x1 mm ²
Process connection	CLM-40N-40-F5-I-_ CLM-40N-40-G-I-_	Flange with 5 holes Thread G1"
Cable gland	CLM-40N-40-_-I-V CLM-40N-40-_-I-H	cable gland with spiral relief cable gland for protective hose
Weight (exclude electrode)		Approx. 0,3kg

MATERIAL PERFORMANCE	
Sensor part	Standard material
Housing	stainless st. W. Nr. 1.4301 (AISI 304)
Cable gland	PA
Cable insulation	PUR
Electrode	stainless st. W. Nr. 1.4301 (AISI 304)
Reference tube	stainless st. W. Nr. 1.4301 (AISI 304)
Process flange	stainless st. W. Nr. 1.4301 (AISI 304)
Insulating bushing	PA + GF30

Dinel[®]

industrial electronics

Dinel, s.r.o.

U Tescomy 249
760 01 Zlín
Czech Republic

Tel.: +420 577 002 003
Fax: +420 577 002 007
E-mail: sale@dinel.cz

www.dinel.cz

The latest version of this instruction manual can be found at www.dinel.cz

Version:10/2015



QMS
ISO 9001

