

- For continuous measurement of liquids in non-pressure tanks, vessels and pipes
- Intended for various liquids (water, oil, coolants, water solutions, etc.)*
- High long-term stability
- Accuracy 0,5% within the total range
- Measuring range up to 100 m (H₂O)
- Thread process connection
- Current or voltage output
- LED indicators



The hydrostatic level meter **HLM-35** is a compact measuring device containing a ceramic or stainless steel strain gauge sensor and evaluation electronics in a stainless steel probe. The ceramic sensor is resistant to different against various liquids (water, oil, coolants, water solutions, etc.). The probe is produced in a configuration with a valve or a capillary, which serves to deliver atmospheric pressure to the probe. The front side of the probe is open, which makes the level meter more resistant against adhesion of coarser soiling. The level meter does not include any elements that can be set. LED signal function.

VARIANTS OF SENSORS

- **HLM-35N-CV** **measuring range 1 ... 100 m H₂O, arbitrary** standard measuring range (can be custom set in 10 cm increments). Current (4 ... 20 mA) or voltage (0 ... 10 V) output. **Sensor with ceramic** converter membrane. **Pressure equalisation via a valve.**
- **HLM-35N-CK** **measuring range 1 ... 100 m H₂O, arbitrary** standard measuring range (can be custom set in 10 cm increments). Current (4 ... 20 mA) or voltage (0 ... 10 V) output. **Sensor with ceramic** converter membrane. **Pressure equalisation via a capillary.**
- **HLM-35N-SV** **measuring range 1 ... 100 m H₂O, arbitrary** standard measuring range (can be custom set in 10 cm increments). Current (4 ... 20 mA) or voltage (0 ... 10 V) output. **Sensor with stainless steel** converter membrane. **Pressure equalisation via a valve.**
- **HLM-35N-SK** **measuring range 1 ... 100 m H₂O, arbitrary** standard measuring range (can be custom set in 10 cm increments). Current (4 ... 20 mA) or voltage (0 ... 10 V) output. **Sensor with stainless steel** converter membrane. **Pressure equalisation via a capillary.**

* If the level meter is used on a liquid other than water, it is necessary to make correction of output current (resp. voltage) according to the density of measured liquid.

DIMENSIONAL DRAWING

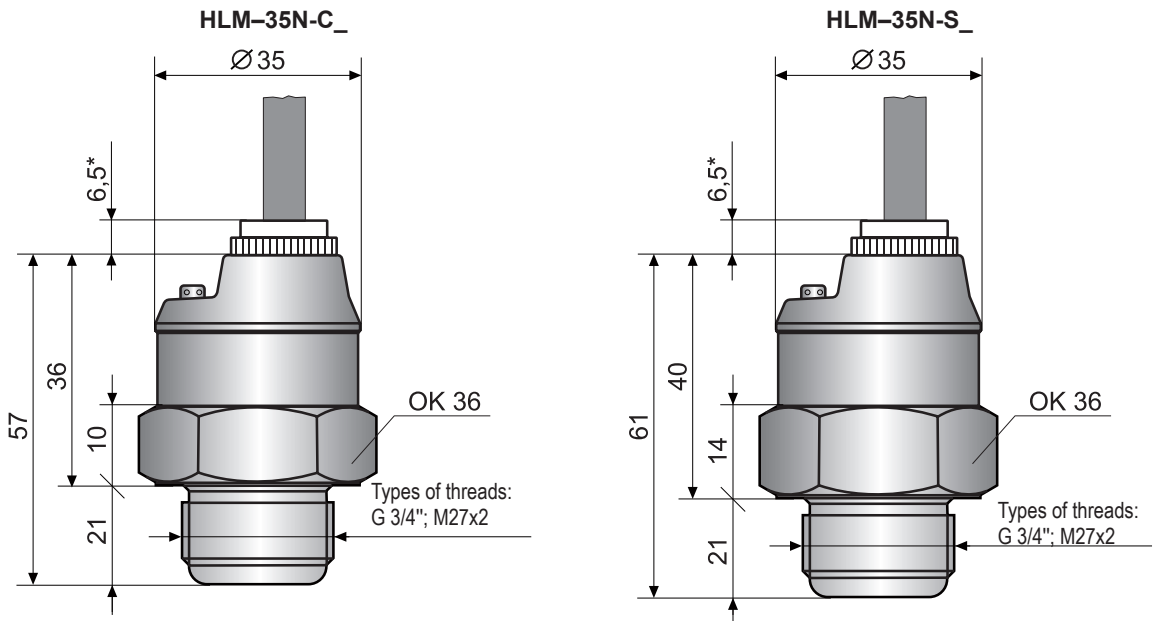

* According to el. connection type

Variant "A" with short stainless steel terminal

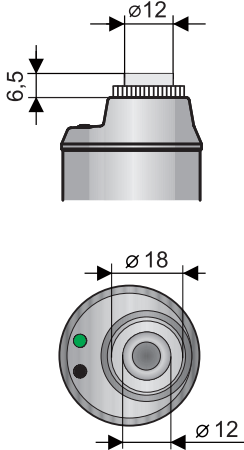

Variant "B" with plastic threaded terminal

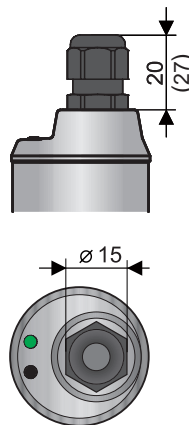

Variant "C" with connector M12

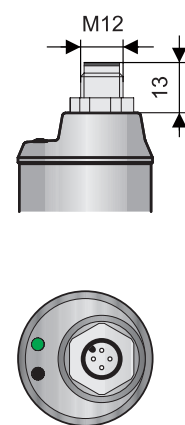

Variant "V" with plastic terminal with spiral relief – in case of increased mechanical strain on the cable.

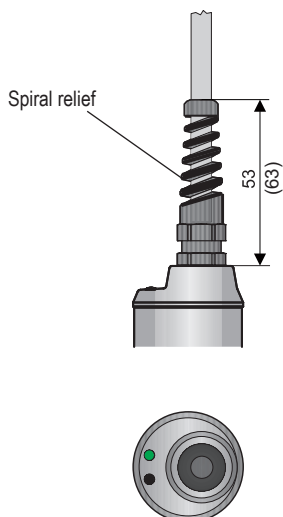

Variant "H" with terminal for protected hoses – for use in outdoor environments or in areas with increased moisture.

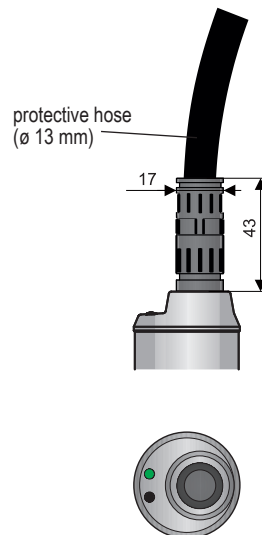

Note. Values in brackets apply for version with the capillary (CK and SK)

TECHNICAL SPECIFICATIONS

BASIC TECHNICAL DATA		
Working environment (EN 60079-10-1)		no explosive hazard area
Supply voltage	HLM-35 _ _ _ _ -I- _ _ _ _ HLM-35 _ _ _ _ -U- _ _ _ _	12 ... 34 V DC 12 ... 34 V DC
Current output	HLM-35 _ _ _ _ -I- _ _ _ _	4 ... 20 mA
Voltage output	HLM-35 _ _ _ _ -U- _ _ _ _	0 ... 10 V
Consumption (empty voltage output)	HLM-35 _ _ _ _ -U- _ _ _ _	max. 8 mA
Permissible overload		1.5x of range
Basic accuracy (non-linearity, hysteresis, repeatability)		0.5% of range
Long-term stability		0.3% / year
Temperature error for zero and range between 0 ... +50°C		max. 0.04% / K
Temperature compensation range		0 ... +50°C
Operating temperature range (temperature of the media)		-20 ... +70°C
Max. load resistance for current output (at U = 24 V DC)		$R_{max} = 600 \Omega$
Min. load resistance for current output		$R_{min} = 1 k\Omega$
Protection class	type HLM-35 _ _ _ _ -C- _ _ _ _ type HLM-35 _ _ _ _ -(A,B,V,H)- _ _ _ _	IP67 IP68
Cable	type HLM-35 _ _ V- _ -I- _ _ _ _ type HLM-35 _ _ V- _ -U- _ _ _ _ type HLM-35 _ _ K- _ -I- _ _ _ _ type HLM-35 _ _ K- _ -U- _ _ _ _	PVC 2 x 0.75 mm ² PVC 3 x 0.5 mm ² PE 2 x 0.25 mm ² with capillary PE 3 x 0.25 mm ² with capillary
Weight	sensor cable (1 m)	190 g 60 g

USED MATERIALS		
part of the sensor	type	standard material
Housing	all	stainless steel W.Nr. 1.4571 (AISI 316 Ti)
End of sensor	all	stainless steel W.Nr. 1.4301 (AISI 304)
Membrane	HLM-35 _ -CV- _ - _ _ _ _ HLM-35 _ -CK- _ - _ _ _ _ HLM-35 _ -SV- _ - _ _ _ _ HLM-35 _ -SK- _ - _ _ _ _	ceramic Al ₂ O ₃ 96% ceramic Al ₂ O ₃ 96% stainless steel stainless steel
Gasket O-rings	all	FPM
Cable terminal	HLM-35 _ _ _ _ -A- _ _ _ _ HLM-35 _ _ _ _ -B- _ _ _ _ HLM-35 _ _ _ _ -V- _ _ _ _ HLM-35 _ _ _ _ -H- _ _ _ _	stainless steel W.Nr. 1.4301 (AISI 304) plastic PA / NBR plastic PA / NBR plastic PA / NBR
Connector M12	HLM-35 _ _ _ _ -C- _ _ _ _	nickel-plated brass

PROCESS CONNECTION		
name	dimensions	marking
pipe thread	G 3/4"	G 3/4
Metric thread	M27x2	M27

RANGE OF APPLICATION

For continuous level measurement of clean, lightly soiled or turbid water in non-pressure vessels. Further for various liquids (oil, coolants, etc.). If the level meter is used on a liquid other than water, it is necessary to make correction of output current (resp. voltage) according to the density of measured liquid. We recommend consulting the suitability of the level meter for measuring other liquids, than H₂O with the manufacturer.

INSTALLATION INSTRUCTIONS

- Installation by screwing into the wall of the vessel of the measured area.
- When using the cable containing the equalising **capillary**, it is necessary to use a **non-hermetic** connection box for connection to connecting cables.
- For CK and SK type level meter, when winding up excess cable into rolls, a diameter of min. 30 cm must be maintained. We do **not recommend** shortening or otherwise mechanically adjusting the cable.
- In tanks, where swirling of the liquids occurs as a result of strong inflow or mixing, it is necessary to place the probe in a stilling pipe, behind a partition or at least as far away as possible from the source of the swirling.
- When using it for **liquids other than water**, it is necessary to make a **correction** to the output voltage respecting the density of the measured liquid, and if necessary consult the application with the manufacturer.

ELECTRICAL CONNECTION



Electrical connection can only be made in a voltage-free state!

In the event that the level meter is fitted with a shielded cable, it is necessary to ground the cable on the side of the power source for the event of a possible lightning electrical discharge in the vicinity of the sensor.

In the event that the level meter is installed in an outdoor environment at a distance greater than 20 m from the outdoor switchboard, or from an enclosed building, it is necessary to supplement the electrical cable leading to the level meter with suitable overvoltage protection.

In case of strong ambient electromagnetic interference, paralleling of conductors with power distribution, or for distribution to distances over 30m, we recommend using a shielded cable and its grounding on the side of the power source.

Level meters HLM-35 with a type A, B, V or H cable terminal, are connected to the assessment units permanently by a connection cable, see pg. 2.

Level meters HLM-35 with connection method type C (see pg. 2) are connected to assessing units by means of a connector socket with a press-in cable, or by means of a detachable connector socket without a cable (see accessories), the connector is not part of the sensor. In this case the cable is connected to the inside pins of the socket according to the figure below.

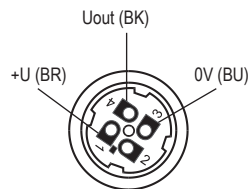

Inside view of the connector socket (variant "C")

In case of use **cable with capillary** connect the positive pole (+U) of the power supply to the red wire *RD*, or connector pin no. 1, the negative pole (0 V) to the black wire *BK*, or connector pin no. 3, and the output voltage (Uout) to the blue wire *BU*, or connector pin no. 4. Connection diagrams are provided in the figures below.

In case of use **cable without capillary** connect the positive pole (+U) of the power supply to the brown wire *BR*, or connector pin no. 1, the negative pole (0 V) to the blue wire *BU*, or connector pin no. 3, and the output voltage (Uout) to the black wire *BK*, or connector pin no. 4. Connection diagrams are provided in the figures below.

Level meter connection with current output

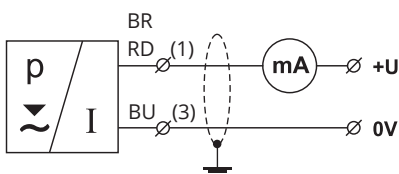

(1...) – Connector terminal numbers

Cable wire colours with a pressed connector:

BR – brown
BK – black

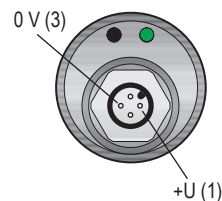

Cable wire colours with capillary:

RD – red
BK – black
---- – shielding

Level meter connection with current output

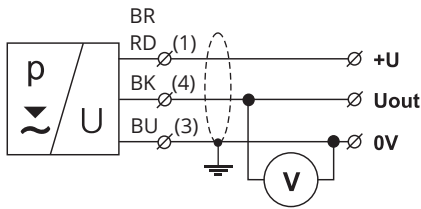

Cable wire colours with a pressed connector:
 BR – brown
 BU – blue
 BK – black

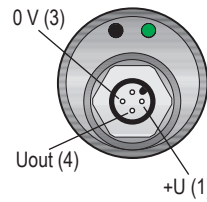

Cable wire colours with capillary:
 RD – red
 BU – blue
 BK – black
 ---- – shielding

(1...) – Connector terminal numbers

FUNCTION AND STATUS INDICATION

diode	Measuring function indication
green	flashing – level measurement functioning correctly dark – incorrect installation or malfunction

CONNECTION EXAMPLES

CONNECTION OF LEVEL METER HLM-35-C-I WITH CURRENT OUTPUT TO THE UNIT PDU-4xx-P (OUTPUT 4 ... 20 mA) USING JUNCTION BOX NB

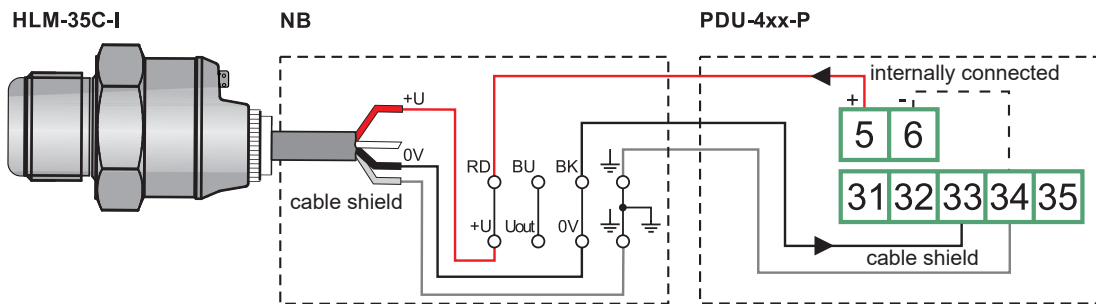

In the case using a connection box with integrated overvoltage protection, the sensor needs to be connected to the bottom series of terminals. This series of contacts is marked by label SENSOR.

CONNECTION OF LEVEL METER HLM-35-C-U WITH VOLTAGE OUTPUT TO THE UNIT PDU-4xx-P (OUTPUT 0 ... 10 V) USING JUNCTION BOX NB

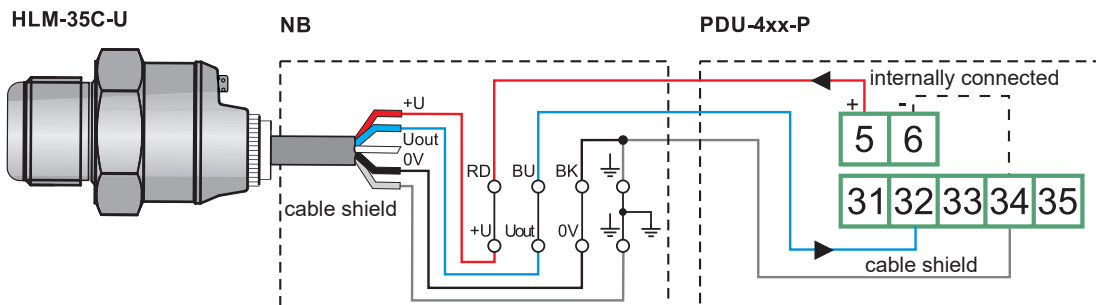

In the case using a connection box with integrated overvoltage protection, the sensor needs to be connected to the bottom series of terminals. This series of contacts is marked by label SENSOR.

Legend:

- RD – red
- BU – blue
- BK – black
- — cable shield

CONNECTION OF LEVEL METER HLM-35-C-I WITH CURRENT OUTPUT TO THE UNIT PDU-4xx-W (OUTPUT 4 ... 20 mA) USING JUNCTION BOX NB

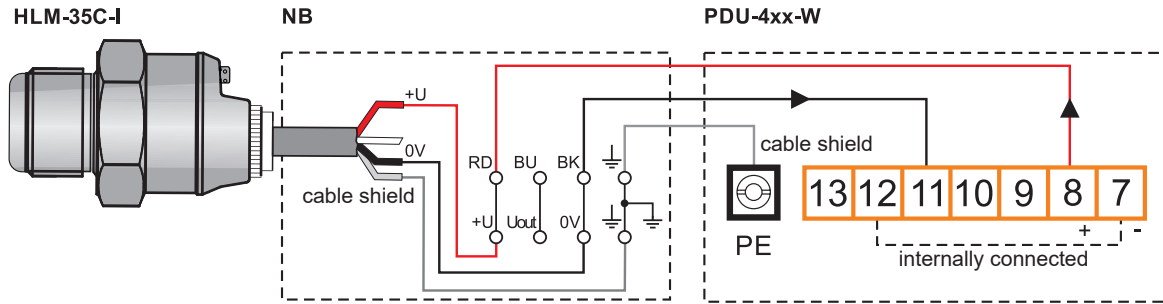

In the case using a connection box with integrated overvoltage protection, the sensor needs to be connected to the bottom series of terminals. This series of contacts is marked by label SENSOR.

CONNECTION OF LEVEL METER HLM-35-C-U WITH VOLTAGE OUTPUT TO THE UNIT PDU-4xx-W (OUTPUT 0 ... 10 V) USING JUNCTION BOX NB

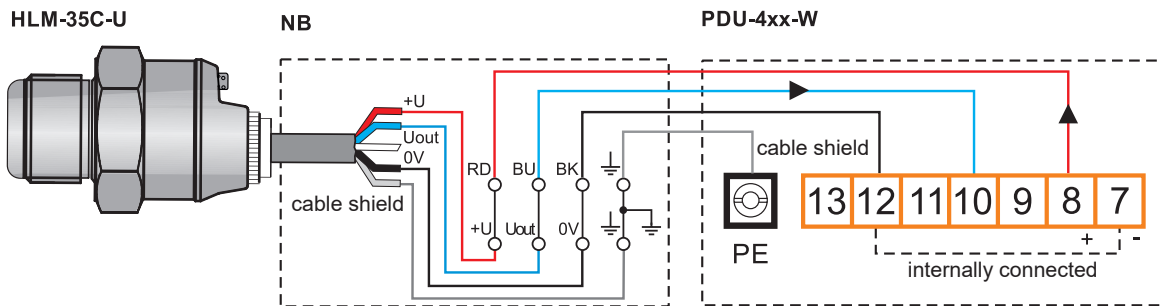

In the case using a connection box with integrated overvoltage protection, the sensor needs to be connected to the bottom series of terminals. This series of contacts is marked by label SENSOR.

ORDER CODE

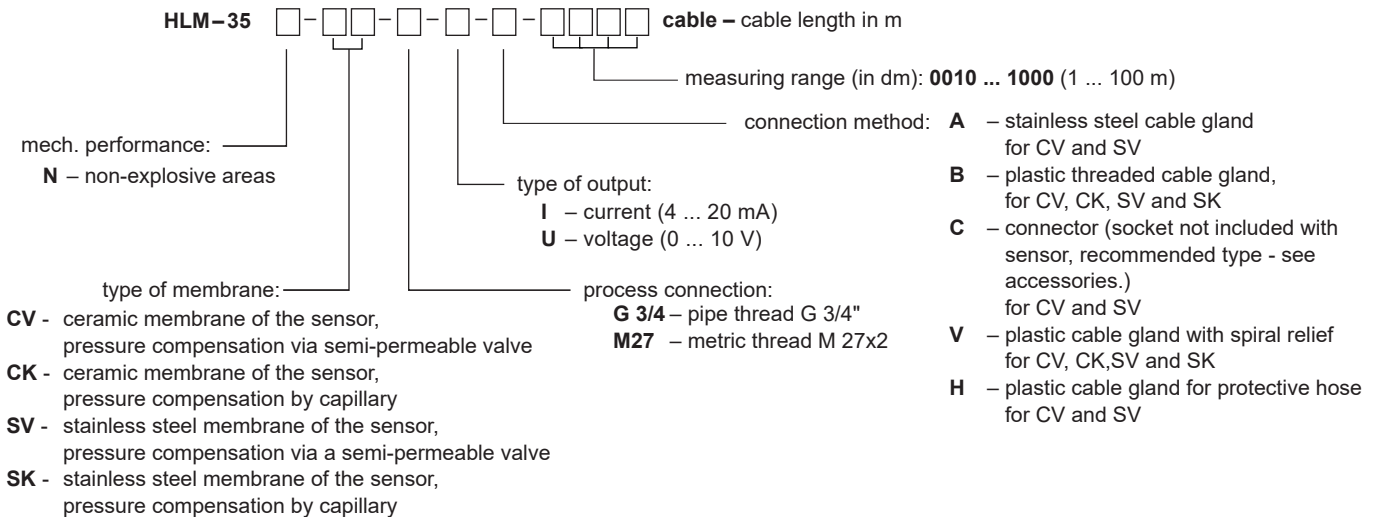

CORRECT SPECIFICATION EXAMPLES

HLM-35N-CV-G3/4-I-A-0010 cable 3 m

(N) non-explosive areas; (CV) ceramic converter membrane with pressure equalizer; (G 3/4) process connection with thread G3/4"; (I) current output 4...20 mA; (A) stainless steel terminal. **Range 1 m**, cable 3 m.

HLM-35N-CK-M27-U-A-0500 cable 52 m

(N) non-explosive areas; (CK) ceramic converter membrane with capillary; (M27) process connection with thread M27; (U) voltage output 0...10 V; (A) stainless steel terminal. **Range 50 m**, cable 52 m.

ACCESSORIES

optional – for a surcharge (see catalogue sheet of accessories)

- cable (over the standard length 2m)
- connector socket (type ELWIKa or ELKA)
- non-hermetic connection box NB
- standard steel or stainless steel welding flange
- protective hose (for type of cable outlet H)
- stainless steel fixing nut
- various types of seals (PTFE, Al, etc.)

SAFETY, PROTECTIONS AND COMPATIBILITY

Level meter HLM-35 is equipped with protection against voltage polarity reversal, protection against current overload and protection against short term overvoltage.

Protection against dangerous contact is provided by low safety voltage according to 33 2000-4-41.

Electromagnetic compatibility is provided by conformity with standards EN 55011/B, EN 61326-1, EN 61000-4-2, -4-3, -4-4, -4-5 and -4-6.

PACKAGING, SHIPPING AND STORAGE

The HLM-35 device is supplied packaged in a cardboard box that protects it against mechanical damage.

When handling and during transport, it is necessary to prevent impacts and falls.

The HLM-35 electrical device must be stored in dry enclosed areas with humidity up to 85%, free of aggressive vapours at temperatures between -25°C and 70°C, and must be protected against the effects of weather.