



PROGRAMMABLE CONTROL UNIT PCU-100



Before the first use of the unit, read the instructions in this manual and keep it carefully. The manufacturer reserves the right to do alteration without prior notice.

CONTENTS

| | |
|---|----|
| 1. Basic description | 3 |
| 2. Application areas | 4 |
| 3. Unit's variants | 4 |
| 4. Dimensional drawing | 4 |
| 5. The front panel and terminal block | 5 |
| 6. Installation instructions | 5 |
| 7. Mechanical mounting..... | 5 |
| 8. Electrical connection..... | 6 |
| 9. Settings..... | 8 |
| 9.1. Configuration of the measurement entry of the unit | 9 |
| 9.2. Display configuration..... | 10 |
| 9.3. Conversion Rules..... | 13 |
| 9.4. Output Relay | 19 |
| 9.5. The archiving and data export configuration | 21 |
| 9.6. Other configuration..... | 22 |
| 9.7. Menu Structure..... | 25 |
| 10. Functions of the equipment | 28 |
| 10.1. Description of the front panel | 28 |
| 10.2. Signalling functions | 29 |
| 10.3. Export of data..... | 29 |
| 10.4. Displaying Functions of the User Menu | 30 |
| 11. Order code..... | 32 |
| 12. Correct specification examples..... | 32 |
| 13. Safety, protections, compatibility and explosion proof..... | 32 |
| 14. Use, manipulation and maintenance | 32 |
| 15. General, conditions and warranty..... | 33 |
| 16. Marking of labels | 33 |
| 17. Technical specifications | 34 |
| 18. Packing, shipping and storage | 35 |

SYMBOLS USED

In order to ensure maximum safety of control processes, we have defined the following safety and information instructions. Each instruction is marked with a corresponding pictogram.



Caution, warning, danger

This symbol informs about particularly important instructions for the installation and operation of the equipment or dangerous situations that may occur during installation and operation. Ignoring these instructions may be the cause of the fault, damage to or destruction of the equipment or may cause damage to health.



Information

This symbol indicates particularly important device characteristics and recommendations.



Note

This symbol indicates the useful additional information.

SAFETY



All the operations described in these operating instructions must be made only by trained personnel or by an authorised person. Warranty and post-warranty repairs must be carried out exclusively at the manufacturer.

Incorrect sensor use, assembly or configuration may cause accidents in the application (tank overfilling or damage to the system components).

The manufacturer is not responsible for the improper use, working losses incurred by either direct or indirect damage and the expenditure incurred during the installation or the use of the sensor.

1. BASIC DESCRIPTION

Programmable control unit PCU-100 is used for measurement, displaying and archiving of the physical value (liquid level, pressure, flow, temperature, etc.). One transducer of physical magnitude with an analogue 4-20 mA output can be connected to the unit.

Different types of conversion (converting) characteristics (linear, square, root and user defined), may be selected, also the tank dimensions for conversion to the volume of the media may be specified. The unit is also available in the version without graphic LCD display that is replaced with the status LEDs. The unit has a battery backed real-time circuit. Archiving with user-defined period takes place on the internal flash memory with a capacity sufficient for more than 500,000 samples. Data can be exported to a micro SD card for additional processing.

User configuration is possible through a regular desktop application after connecting a PC via a micro USB connector located on the front panel of the unit. For the version fitted with an LCD display the configuration is also possible using the graphical menu and four membrane keys.

The unit is equipped with one input settings in the hardware configuration according to the type of unit. One relay output is fully user-configurable, including the possibility of two-state control. The functionality of the unit is expandable with optional modules. The units are built into the ABS/PC instrument boxes intended for wall mounting. Connection terminal is located inside the device.

2. APPLICATION AREAS

Programmable control unit can be used as a universal industrial data logger for monitoring of a measured value. Thanks to a relay output, it is also possible to use the unit for the control of the process of measured value using two-state control.

3. UNIT'S VARIANTS

The unit is available in two versions. The makes are different by the front panel appearance. Both versions have a micro USB connector to connect a computer to configure the unit via the configuration application and micro SD card slot for the purposes of exports of the recorded data.

- **PCU-100-D** Front panel with a **graphic LCD display and a membrane keypad**. The entry depending on configuration (for connecting one sensor), one relay output.
- **PCU-100-L** The front panel without an LCD display with **status LEDs**. The entry depending on configuration (for connecting one sensor), one relay output

4. DIMENSIONAL DRAWING

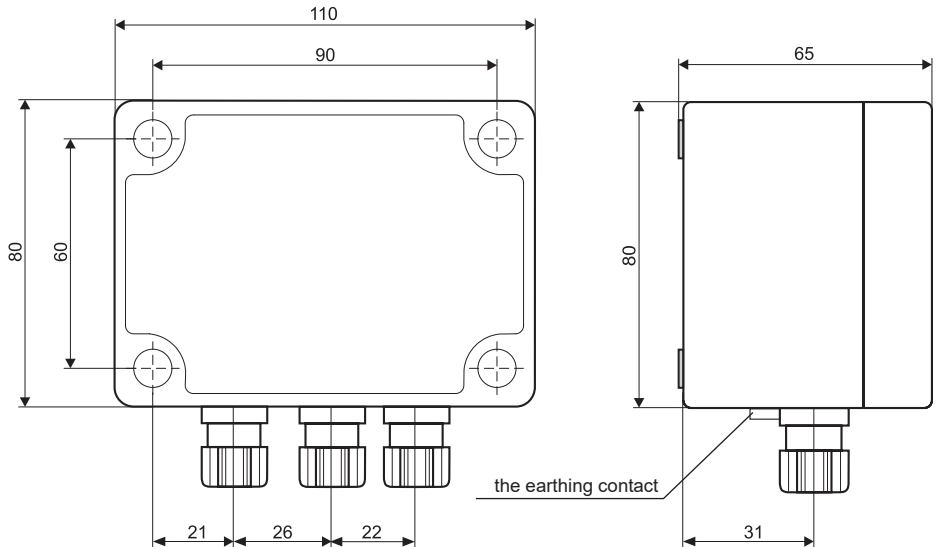

5. THE FRONT PANEL AND TERMINAL BLOCK

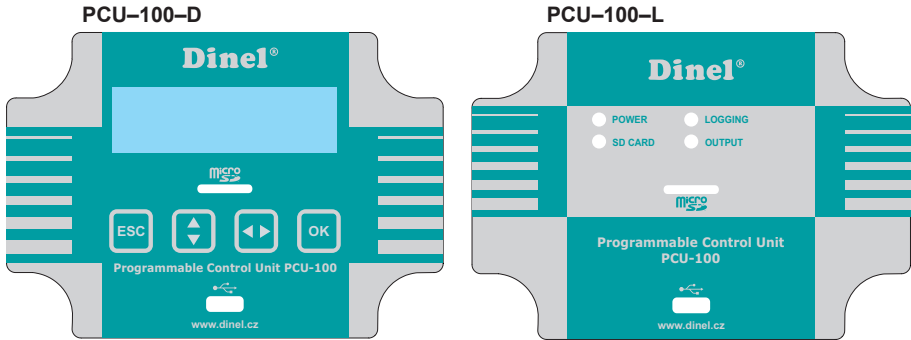

Terminal Block: PCU-100-X-I:

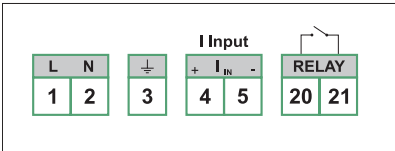

| No. of terminal | |
|-----------------|-------------------------|
| 1 | L (85 - 253 VAC) |
| 2 | N (85 - 253 VAC) |
| 3 | ⏚ Functional earthing |
| 4 | Current input + |
| 5 | Current input - |
| 20 | RE 1 (100 mA / 250 VAC) |
| 21 | RE 1 (100 mA / 250 VAC) |

6. INSTALLATION INSTRUCTIONS

This procedure has the following three steps:

- **MECHANICAL MOUNTING - SEE CHAPTER 7**
- **ELECTRICAL CONNECTION - SEE CHAPTER 8**
- **SETTINGS - SEE CHAPTER 9**

7. MECHANICAL MOUNTING

- A number of evaluation units PCU-100-X is designed to be installed on a wall using four mounting screws or bolts (hereinafter referred to as "the screws").
- When installing the device, it is first necessary to withdraw the transparent polycarbonate housing of the front panel that is held in place by 4 plastic screws. The mounting holes designed for screws for attaching to the wall are located under the plastic screws. Using the screws, the unit is fixed in the required position on the wall. Now, it is possible to connect the cables to the terminals.
- Then, return the transparent cover to the place on the front panel and its plastic screws are sufficiently tightened to achieve full coverage.
- The prescribed tightening torque is 3 Nm.



Be extremely careful when placing the cover in place. It is not possible to settle the front cover arbitrarily, there are located protrusions on the bottom of the housing and on the body of the boxes. At bad settlement, these protrusions may prevent the full engagement of the seal and the achievement of full coverage.

8. ELECTRICAL CONNECTION

The electrical connection is made to the terminal block of the device. For an access to the terminal block, it is required:

1. Remove the transparent front polycarbonate housing (see chapter Mechanical assembly)
2. Grip the front panel on the sides by the grips intended for this purpose (see figure below)
3. Pull evenly on both sides to eject the front panel from the connector.

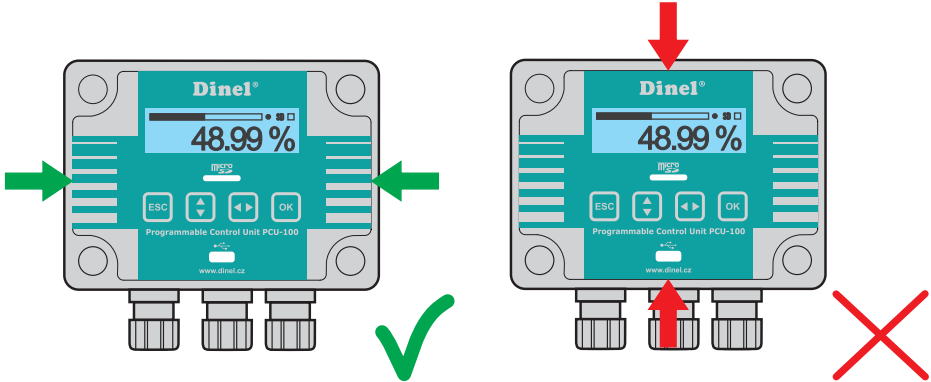

Electrical connection can only be made in a voltage-free state!

The temperature of the internal components of the unit may under specific conditions exceed a temperature of 60°C after a longer period of time in service. Take care when handling.

- The device may only be connected to the power supply via an easy to reach switch with marked turned off/on positions and must be protected by a fuse or circuit breaker with a value of max. 16 A!



The switch or circuit breaker used as the disconnect device must be in accordance with the IEC60947-1 and IEC60947-3, must be marked and must not be in the network inlet.

- The used connecting cables must be of circular cross-section of the prescribed diameter (2.5 - 6.5 mm). The connection cable must be according to the specifications of the manufacturer rated to the operating voltage (85 - 253 VAC) and the current load corresponding to the rated wattage (6 VA) at this voltage. The insulation material must comply with the operating voltage and endure the ambient temperatures of up to 70 °C. In the case, there is no cable in the penetration, the penetration must be fitted with a plug. Cable grommets must be tightened to the specified torque (3 Nm).

WIRING CONNECTIONS

| | |
|---|--|
| Power supply inlet | power supply AC lead "L" to the terminal No.1 and lead "N" to the terminal No.2. |
| Connections of input equipment | current loop "+" to terminal No. 4 and "-" to No. 5 |
| Relay output (galvanically separated solid state relay - SSR) | the connection to the terminals No.6 and No.7. |



The external power supply is not connected

- Grounding wire connected to the unit serves always as the functional ground to improve the assembly resistance against EM interference and does not fulfil the protective function. Connection of a functional earth to the unit is possible in one of the two ways while we are choosing the way that allows connection the ground wire on a shorter route:
 1. We will connect the grounding wire inside the unit to the terminal number three where it is assumed to bring the earthing wire to the unit within the power cable.
 2. The grounding wire will be connected to the external earth terminal of the device, which is located on the bottom of the box together with outlets.



The grounding wire is always attached only in one place by using the method 1 or 2. It is never attached in both places at the same time.

Example connection:

An example of the PCU-100-X-I unit connection with the level sensor ULM-53-xx-I is shown here.

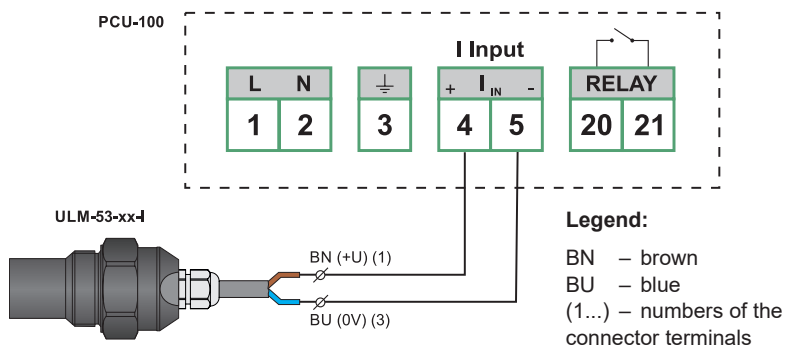

The level transmitter ULM-53-XX-I may be replaced by any other sensor with current output.

Example of a circuit with shielded cable:

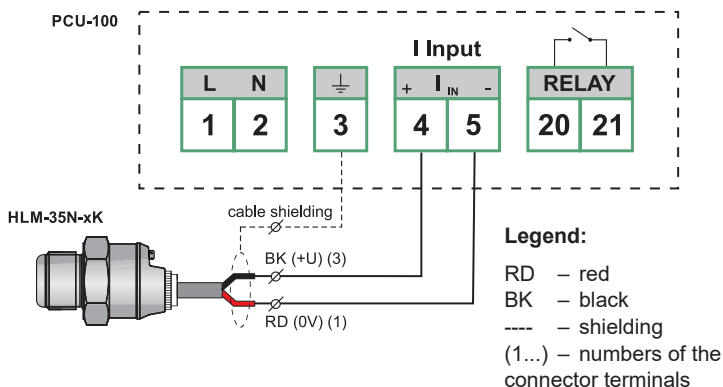

9. SETTINGS

The units in the version PCU–100-D with LCD display can be set using the graphical menu controlled by four membrane keys. For access to the control buttons and USB connector, it is necessary to withdraw first the transparent polycarbonate housing of the front panel that is held in place by 4 plastic screws. (see Chapter Mechanical assembly)



Be extremely careful when placing the cover back in place. It is not possible to settle the front cover arbitrarily, there are located protrusions on the bottom of the housing and on the body of the boxes. At bad settlement, these protrusions may prevent the full engagement of the seal and the achievement of full coverage.

A detailed description of the configuration using the user menu is the subject of this chapter. The unit can also be configured by means of a configuration application for PC. For connection of the unit to your computer, a micro USB connector is designed on the front panel of the unit. The description of the configuration with this application is the subject of the user manual for this application.

The basic functions of buttons and their symbols



The symbol used in the manual: **[ESC]**

Functionality:

- The procedure in the menu one level up
- Change cancelling when editing



The symbol used in the manual: **[↑]**

Functionality:

- The shift in the menu
- Increase of the highlighted character value on the screen for entering the values



The symbol used in the manual: **[←→]**

Functionality:

- The shift in the menu
- Shift between the characters on the screen for entering the values
- Change the value of the check mark at the menu item
- Change the value on the screen with the values selection



The symbol used in the manual: **[OK]**

Functionality:

- Entering the main menu
- Entering the sub-menu
- Confirming changes when editing



If no key is pressed within 5 minutes in the menu, the unit automatically switches back to the display mode.

Entry to the menu and scrolling through the menus

The entry to the menu is performed by pressing the **[OK]** button. By pressing briefly the button **[↑]** we are moving in the sub-menu, we get to the next level by pressing **[OK]**. The edited data can be changed using the arrows **[↑]** **[↔]**. The changes are saved with the **[OK]** button, back to the main menu, we get by pressing the button **[ESC]**.

9.1. CONFIGURATION OF THE MEASUREMENT ENTRY OF THE UNIT

For a correct display of bar graph and for the purpose of the transfer characteristics configuration it is necessary to specify the bounds of the measuring range of the unit, thus, minimum value of the input magnitude (corresponds to 0 %) and its maximum value (corresponds to 100 %).

The measuring range can be also configured inversely, when minimum of the range corresponds to a greater level of the input value than the maximum of the range.

Deviation of values outside the measuring range is indicated on the display of the unit by the text "Below the range"/"Above the range". However, the conversion of the value for display and archiving takes place also within the limits of the extended measuring range, if configured. Outside the extended measuring range is logged and displayed the value -N/A (below the minimum) or +N/A (above the maximum).

The extended measuring range can be configured identically as the measuring range. In this way the unit behaves even if the limits of the extended measuring range of the wrongly configured senselessly (in the area of the measuring range or inverted).

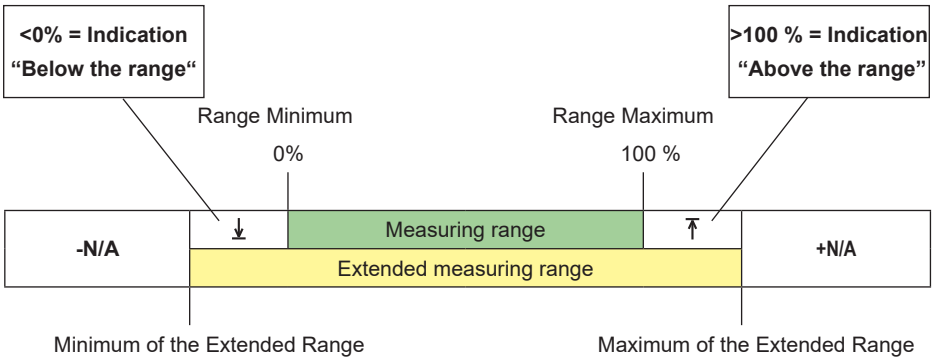

THE DEFAULT CONFIGURATION OF THE MEASURING RANGE ACCORDING TO THE UNIT'S INPUT

| Type of unit inlet | Measuring range minimum | Measuring range maximum | Extended measuring range minimum | Extended measuring range maximum | Limits of the user configuration |
|--------------------|-------------------------|-------------------------|----------------------------------|----------------------------------|----------------------------------|
| Menu ID | 028 | 029 | 030 | 031 | - |
| Current | 4 mA | 20 mA | 3.85 mA | 20.55 mA | 0 – 24 mA |

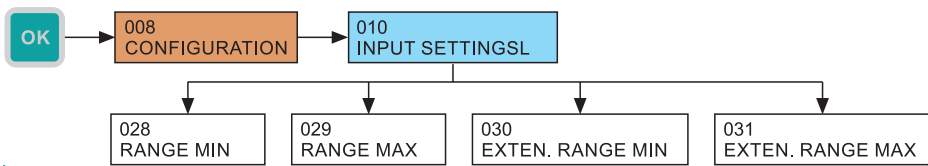

9.1.1. Filtration of the input value

It is suitable to use the filtration function for suppression of the fluctuations in view at fast or jump changes of the input value. The subsequent speed of change of the input value will be dependent on an exponential course. Filtration with defined delay in seconds indicates the time that the exponential curve reaches 2/3 of its maximum value.



To turn off the filtration, it is necessary to configure the value to 0 seconds.

- **Menu: FILTRATION (ID 032)**
- **Default value: 20 sec**
- **Configuration range: 0-999 sec**
- **[↔] - Movement between the characters [↑] - Change of Value**



9.2. DISPLAY CONFIGURATION

9.2.1. Types of the main screen display

The configuration of the main screen graphical style showing the measured value according to the user configuration. The configuration will affect the size of the digits, possible display of the bar graph, date and time. Detailed view is intended more as a diagnostic and, therefore, it shows the value of the input as well as user value with a fixed number of decimals.

Basic 32px



With bar graph 24px

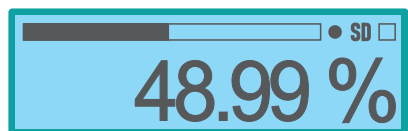

Detailed 8px

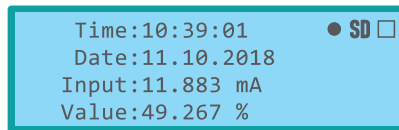

- **Menu: MAIN SCREEN TYPE (ID 020)**
- **Default: Basic 32px**
- **[↔] - Change the display type**

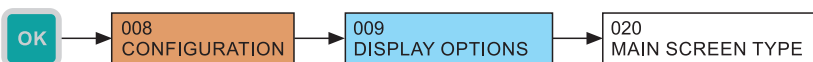

9.2.2. Configuration of the display of decimal places' number

The configuration of a preferred number of decimal places on the main screen. The display takes place with a specified number of decimal places, if the amount of the value of the to display allows it with regard to the number of positions on the display. If there is not enough positions available for display, automatic reduction of the number of decimal places takes place.



The detailed display mode works with a fixed number of decimals and this configuration is not reflected.

- **Menu: DECIMAL PLACES ID (021)**
- **Default value: 2**
- **Configuration range: 0-5**
- **[↑] - Change of value**



9.2.3. The supplementation of the left-hand side of the displayed values

Causes displaying of zeros in free positions in front of the displayed value on the main screen.

- **Menu: ZEROES FROM LEFT (ID 022)**
- **Default value: prohibited**
- **The check mark - change by using [↔] directly in the menu(ID 009)**



9.2.4. Displayed unit

The unit for display on the main screen, the unit is not stored into the memory, to the head of the file with the exported data, there is given only the unit configured at the time of export. It can be selected out of seventeen predefined units + user-defined units.

| PREDEFINED UNITS | | | | | |
|------------------|-----|-------------|----|-------------------|----------------|
| Dimensionless | [-] | Decimetres | dm | Cubic metres | m ³ |
| Milliamperes | mA | Metres | m | Gallons | gal |
| Volts | V | Inches | in | Barrels | dbl |
| Percentage | % | Feet | ft | Centigrades | °C |
| Millimetres | mm | Litres | l | Degree Fahrenheit | °F |
| Centimetres | cm | Hectolitres | hl | User-defined unit | ???? |

- **Menu: DISPLAYED UNIT (ID 023)**
- **Default: Percentage**
- **[↔] - Changing the unit**



9.2.5. Defining the user unit

It is possible to enter any 4 characters. The here defined unit is then offered the selection of units.

- **Menu: USER UNIT ID (024)**
- **[↔] - Movement between characters [↑] - Change of the character**



9.2.6. The menu language

The unit allows to select a language mutations and currency. Czech or English are available.

- **Menu: MENU LANGUAGE (ID 025)**
- **Default: English**
- **[↔] - Change of value**



9.2.7. Backlight level of the LCD display

Configuration of the LCD backlight level. It is possible to select from nine levels backlight and its full turn-off (0 value).

- **Menu: BACKLIGHT LEVEL (ID 026)**
- **Default value: 3**
- **Configuration range: 0 - 9**
- **[↑] - Change of value**

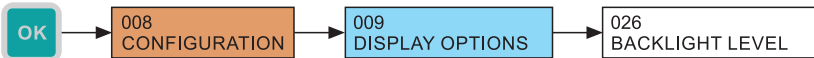

9.2.8. LCD display contrast

Configuration of LCD display contrast. Control electronics of the display uses automatic contrast correction according to the ambient temperature, therefore, in most cases there is no need of adjusting this configuration. However, in extreme cases, it is possible for the user to increase (positive values configuration) or decrease the contrast (negative value settings). The value can be configured in the range from -9 to +9.

- **Menu: CONTRAST (ID 027)**
- **Default value: 0**
- **Configuration range: -9 to 9**
- **[↑] - Change of value**



9.3. CONVERSION RULES

The unit can convert the input value according to a mathematical curve, to a mathematical model of the tank with the specified dimensions or to a user-defined table. There are 3 types of curves and 8 types of tanks.

All types of transfer characteristics work with the value of the input magnitude as a percentage according to the settings of the measuring input of the unit (see section “Configuration of the measurement input of the unit”). The resulting value given by the conversion rules according to user configuration is displayed on the display and stored with the configured period in the internal memory.



If the extended measuring range is configured, conversion takes place also for the negative percentage value entry and values greater than 100 %.

The first step is to configure the desired conversion type and then the parameters of the selected transfer characteristics that are involved in the following sections.

| TYPES OF CONVERSION CHARACTERISTICS | | |
|---|-------------------------|---------------------------|
| Transfer characteristics | Name in the menu | Parameter menu |
| Linear curve | LINEAR CURVE | CURVE PARAMETERS (ID 034) |
| Quadratic curve | QUADRATIC CURVE | |
| Square root curve | SQUARE ROOT CURVE | |
| Vertical rectangular tank with a hopper | VERT. RECT. TANK | TANK DIMENSIONS (ID0 35) |
| Vertical cylindrical tank with a tapered termination | VERT. CYL. TANK TAPERED | |
| Vertical cylindrical tank with spherical terminations | VERT. CYL. TANK SPHER. | |
| Vertical cylindrical tank with ellipsoidal terminations | VERT. CYL. TANK ELLIP. | |
| Horizontal cylindrical tank with flat terminations | HOR. CYL. TANK FLAT | |
| Horizontal cylindrical tank with ASME type terminations | HOR. CYL. TANK ASME | |
| Horizontal cylindrical tank with ellipsoidal terminations 2:1 | HOR. CYL. TANK E2:1 | |
| Horizontal cylindrical tank with half spheric type terminations | HOR. CYL. TANK K1/2 | |
| User defined table | USER TABLE | USER TABLE (ID 036) |

- **Menu: CONVERSION TYPE (ID 033)**
- **Default: Linear curve**
- **[↔] - Change of value**



9.3.1. Transfer by the transfer characteristics

If linear, square or square root characteristics is selected as the conversion type, the resulting value of the conversion is the given by two points. The zero value of input magnitude (I_n) corresponds to the value of the "User minimum" (U_{min}) and the value of 100% input value (I_n) corresponds to the value of the "User maximum" (U_{max}). The resulting user value "W" is throughout the extended user range given by the mathematical dependence given below at the graphical display depending on the input value.



The value of the parameter "User minimum" may be greater than the value of the parameter "User maximum". When you increase the input values then the displayed and logged value decreases.

User minimum (U_{min})

- Menu: **MIN. INPUT VALUE (ID 037)**

Default: 0

User maximum (U_{max})

- Menu: **MAX. INPUT VALUE (ID 038)**

Default: 100

- [\leftrightarrow] - movement between characters [\updownarrow] - The increase of value of the marked digits (at marked decimal comma, a shift by an order occurs)

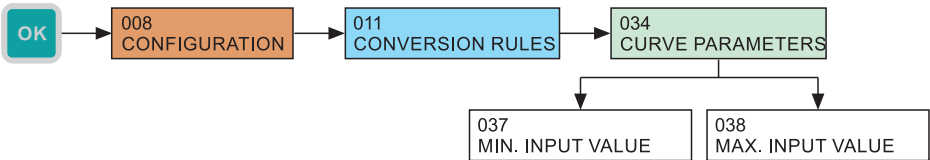

a). The linear characteristics

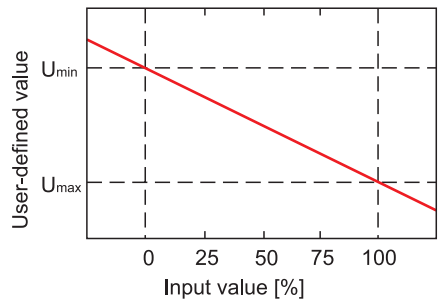
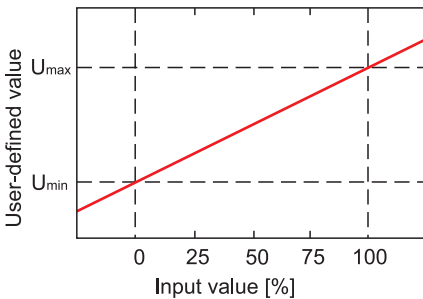

$$W = \frac{I_n[\%]}{100} \times (U_{max} - U_{min}) + U_{min}$$

b). The quadratic characteristics

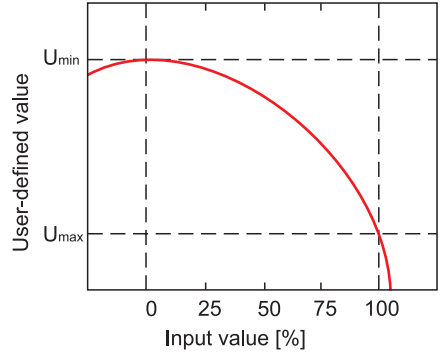
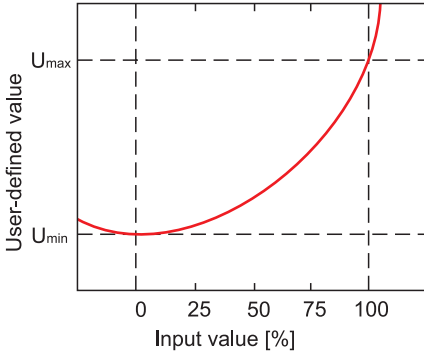

$$W = \left(\frac{I_n[\%]}{100} \right)^2 \times (U_{max} - U_{min}) + U_{min}$$

c). The square root characteristics

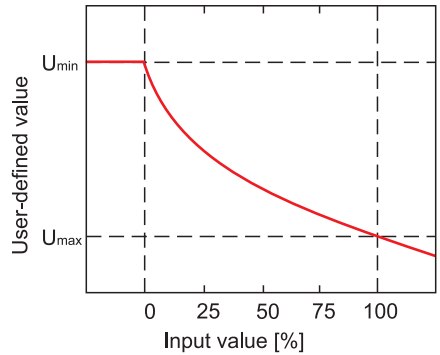
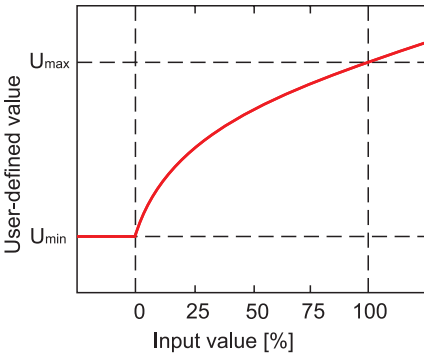

$$W = \sqrt{\frac{I_n[\%]}{100}} \times (U_{max} - U_{min}) + U_{min}$$



The above formula is valid only for non negative value of the input magnitude. If the input value is less than 0, the resulting user value "W" corresponds to the value of the "User minimum".

9.3.2. The tank mathematical model

The unit calculates the volume of the media in the tank according to the selected type and specified dimensions depending on the input value representing the level. Zero level of input (I_n) in per cents match the zero level in the tank. The input value at the level of 100 % represents the full tank.

The relationship between the level height and the input value:

$$h = \frac{I_n[\%]}{100} \times \text{Tank height}$$

If an extended measuring range is specified, then a mathematical model of the tank for the values of input value $<0\%$ keeps the zero value of volume and for values $>100\%$ then the total volume of the tank (the value does no more increase).



If invalid dimension values are entered for the mathematical model of the tank, the model output value is zero regardless of the input value.

For each type of fuel tank, it is necessary to specify its width and height. Furthermore, it is necessary to specify up to three specific dimensions of the given tank as parameters A, B and C. The drawings of individual types of tanks with the specific dimensions are shown at the end of this chapter.

- **Menu: TANK DIMENSIONS (ID 035)**
- **[↔] - Movement between the characters [↑] - Change of Value**

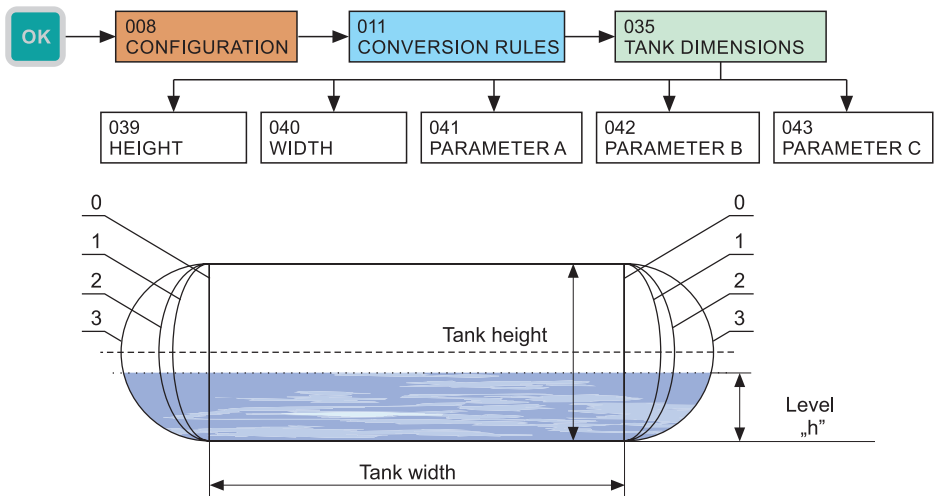

Fig. 1: Horizontal cylindrical tank - adjustable termination

- 0 ... Horizontal cylindrical tank with flat terminations
- 1 ... Horizontal cylindrical tank with ASME type terminations
- 2 ... Horizontal cylindrical tank with ellipsoidal terminations 2:1
- 3 ... Horizontal cylindrical tank with half spheric type terminations

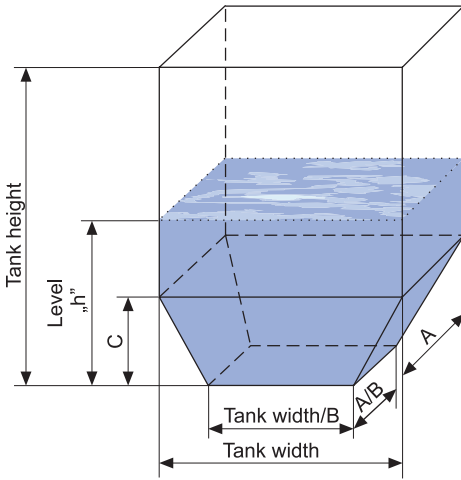

Fig. 2: Vertical rectangular tank with a hopper

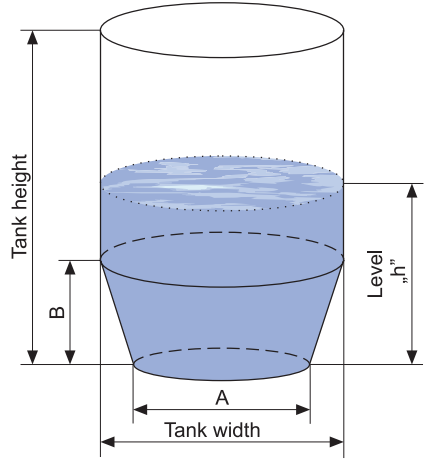

Fig. 3: Vertical cylindrical tank - tapered bottom termination

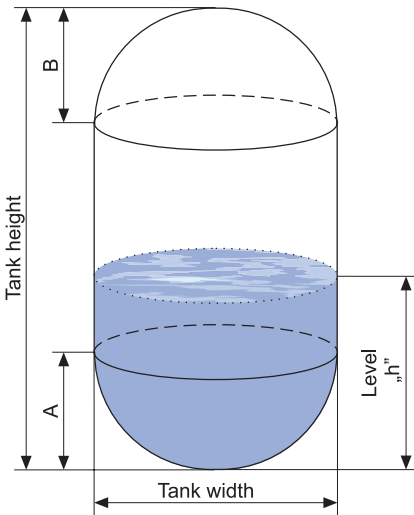

Fig. 4: Vertical cylindrical tank - spherical termination (ball)

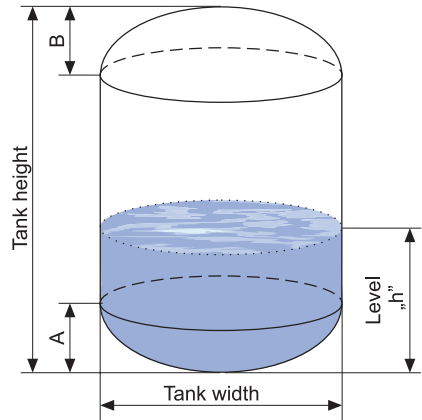
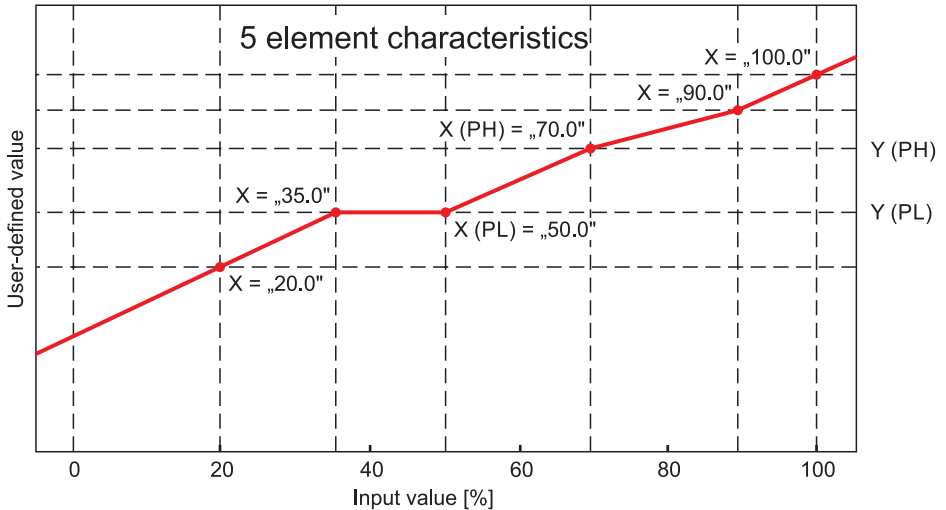

Fig. 5: Vertical cylindrical tank - ellipsoidal termination

9.3.3. User table

User defined characteristics is given as a set of points with coordinates X-Y, where the x coordinate is the value entry in percentages and the y coordinate of the required user value. The number of points is variable and can be configured from 2 to 32 points that make up linear segments. The conversion of the value of the input values less than x coordinate of the first point and greater than x coordinate of the last point is on the line of the two closest coincident points (see chart).



Considering any point of the curve “PL” (low) and the following point “PH” (high), while their x coordinates to describe as X (PL), X(PH) and y coordinates as Y(PL), Y(PH), then the user value “W” in the area between the two points is given by the relation:

$$W = \frac{I_n[\%] - X(PL)}{X(PH) - X(PL)} \times [Y(PH) - Y(PL)] + Y(PL)$$

a). Display of table points

The unit allows to view stored user points. The individual points are numbered from zero to 31. The x coordinate (input value in percent) and the y coordinate (user value) are always displayed.

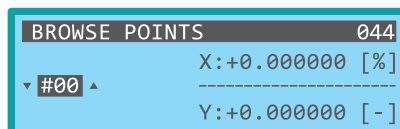

- **Menu: BROWSE POINTS (ID 044)**
- **[↑] - Display of the next point**



b). Adding a point to the user table

Specifying a point into the user table takes place in two steps. In the first step, the X coordinate of the point is specified whose value is continuously updated to the currently measured value of the input magnitude until its manual change or its confirmation. In the second step, the y coordinate of the point is specified.

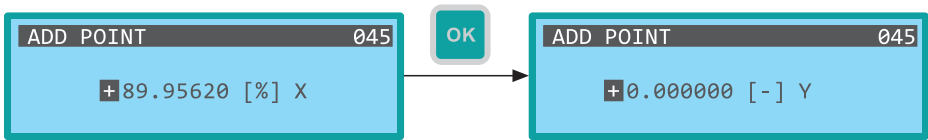

- **Menu: ADD POINT (ID 045)**
- **[↔] - movement between characters [↑] - The increase of value of the marked digits (at marked decimal comma, a shift by an order occurs)**



c). Deleting the last point of the table

The unit allows for deleting the last point added to the table. The unit requires a confirmation of this option by means of a dialogue

- **Menu: DELETE LAST POINT (ID 046)**
- **[↔] - Change of selection YES/NO**



d). Deleting the complete table

Another alternative is the deleting of the entire user table (all points). The unit requires confirmation of this option by means of a dialogue.

- **Menu: DELETE TABLE (ID 047)**
- **[↔] - Change of selection YES/NO**



9.4. OUTPUT RELAY

The unit processes the user value in accordance with the selected processing type. The user has the choice of five options listed in the table below. The evaluation works with the desired value specified by the user. The control process also requires specification of the hysteresis.

9.4.1. Selection of the processing type

- **Menu: PROCESSING TYPE ID (048)**
- **Default value: turned off**
- **[↔] - Change of value**



| PROCESSING TYPES OF USER VALUES FROM THE POINT OF VIEW OF RELAY OUTPUT | |
|--|-----------------------|
| Evaluation turned off | TURNED OFF |
| Alarm - signalling of exceeding the desired value | ALARM - OVER |
| Alarm - signalling of fall under the desired value | ALARM - UNDER |
| Two-state control by the desired value and hysteresis | 2-POS REGULATION |
| Two-state control by the desired value and hysteresis and inverse output | 2-POS REGULATION INV. |

The behaviour of the relay output depending on the user value and on the selected processing type is shown on the following graph. If the evaluation is turned off, the output relay is permanently open.

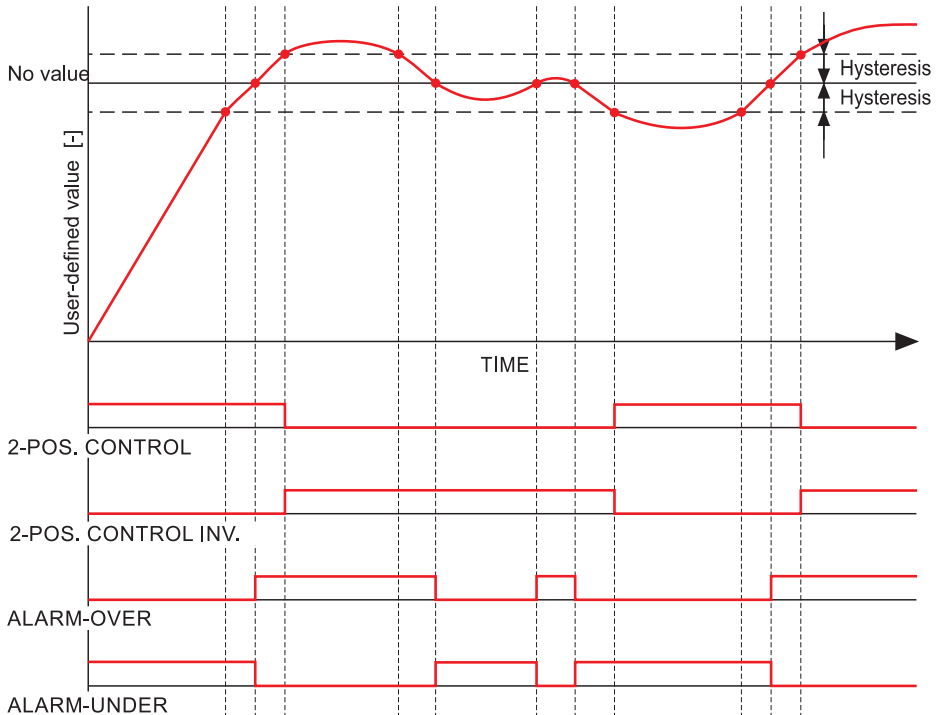

9.4.2. Configuration of the desired value

- Menu: **SETPOINT (ID 049)**
- [↔] - movement between characters [↑] - The increase of value of the marked digits (at marked decimal comma, a shift by an order occurs)

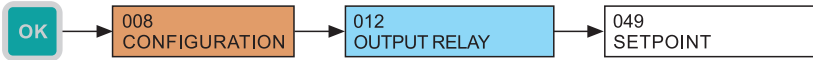

9.4.3. Hysteresis configuration

- Menu: **HYSTERESIS (ID 050)**
- [↔] - movement between characters [↑] - The increase of value of the marked digits (at marked decimal comma, a shift by an order occurs)

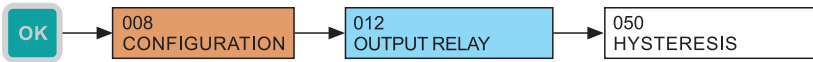

9.5. THE ARCHIVING AND DATA EXPORT CONFIGURATION

9.5.1. Archiving period

The unit stores the data on an internal FLASH memory with a period that the user can configure. The configuration can be in the range 1 second to 8 hours. The value is always entered in seconds. The beginning of this period is always the start of the unit, when the first value is stored after the start.

- Menu: **ARCHIV. PERIOD (ID 013)**
- Default value: 2
- [↔] - Movement between the characters [↑] - Increase of the marked digit value



9.5.2. The automatic data export to the SD card

The unit in default configuration exports internal memory to a file on an SD card immediately after its inserting into the unit's slot. This function can be disabled in the unit's menu. If the automatic export is prohibited, it can be called up in the unit's menu (see chapter 10.3. Data Export).

- Menu: **WHEN INSERTED ID (051)**
- The check mark - change using [↔] directly in the menu.

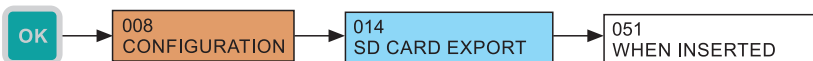

9.5.3. Backup mode configuration

The unit is equipped with an automatic backup function to the internal memory. At the selected events or at the specified time, the data export takes place from the internal memory to an SD card. In the default configuration, the backups are set to automatic mode when the export is made at complete filling of the internal memory, i.e. at the time, when the oldest values will be overwritten by the new ones. This function is only available if there is an SD card inserted in your device. Capabilities of automatic backup are given in the following table.

| MODES OF THE AUTOMATIC BACKUP OF THE INTERNAL FLASH MEMORY | |
|--|-------------------|
| Automatic backup turned off | DISABLED |
| Export at filling up the internal FLASH memory | AUTO (FULL FLASH) |
| Periodic daily export (at midnight) | DAILY (MIDNIGHT) |
| Periodic weekly export of data (at midnight from Sunday to Monday) | WEEKLY (MIDNIGHT) |

- **Menu: BACKUP MODE (ID 052)**
- **Default value: AUTO (FULL FLASH)**
- **[↔] - Change of value**

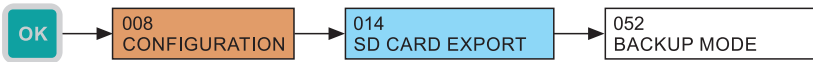

9.6. OTHER CONFIGURATION

9.6.1. Date-time change

The configuration of current date and time for the inner real time circuit can be made on one below shown screens. Active digit is represented by two arrows.

 *If a loss of current information about the date and time takes place, check the internal battery (see Chapter 14 . Use, service and maintenance)*

 **If the date is modified retrospectively, it is recommended to clear the internal Flash memory of the unit, the search of values when browsing the saved data in the unit's menu may not work properly in this case.**

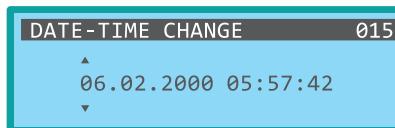

- **Menu: DATE-TIME CHANGE (ID 015)**
- **[↔] - Movement between the characters [↑] - Increase of the marked digit value**



9.6.2. Password change

To change the password for the unit configuration, the current valid password is to be re-entered and then the new password. The password may have up to 9 digits.

| | |
|--|-----------|
| The default password for entry into the configuration part | 000012345 |
|--|-----------|

 It is strongly recommended that you change the default password in operating units.

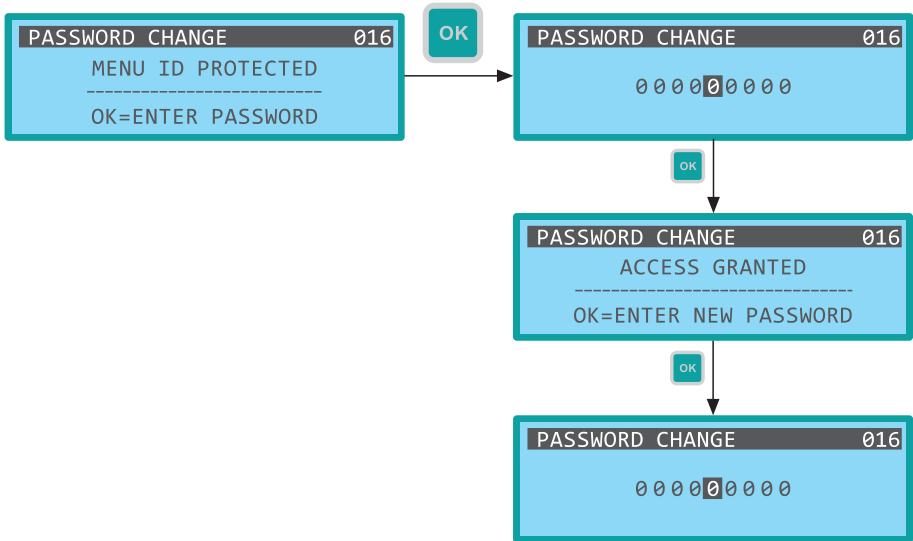

- Menu: **PASSWORD CHANGE (ID 016)**
- [↔] - Movement between the characters [↑] - Increase of the marked digit value

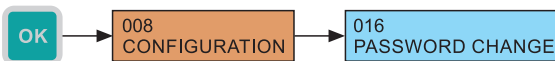

9.6.3. Default Configuration

Placing the unit into the factory default configuration is possible through the below shown menu item after agreement on the confirmation dialogue.

 The action will not affect the logged data in the internal FLASH memory.

 This action is irreversible.

- Menu: **FACTORY DEFAULT (ID 017)**
- [↔] - Change of selection YES/NO



9.6.4. Delete internal FLASH memory

The user can delete the internal FLASH memory of the unit. This action is particularly suitable for the reduction of the exported data file to the SD card if the data were already archived or are no longer needed. For the memory clearing, the reconciliation of confirmation dialogue is necessary.



This action is irreversible.

- Menu: **ERASE FLASH MEM. (ID 053)**
- [↔] - Change of selection YES/NO

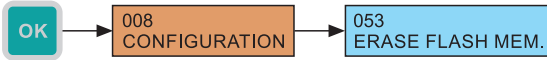

9.6.5. Restart of the device

To restart the device, the user can use the below shown item in the menu. Restart is performed after the reconciliation of confirmation dialogue.



The action will affect neither the unit's configuration nor the data logged in the internal FLASH memory.

- Menu: **RESTART DEVICE (ID 018)**
- [↔] - Change of selection YES/NO



9.6.6. Lock the unit

For the immediate abolition of the access to the adjustment part of the menu, the user can use the following item in the menu. After selecting the item, exiting of the menu takes place and, at the next entry into the menu, the password will be again required for the adjustment part.

- Menu: **EXIT SETUP ID (019)**



9.7. MENU STRUCTURE

Entering the menu:

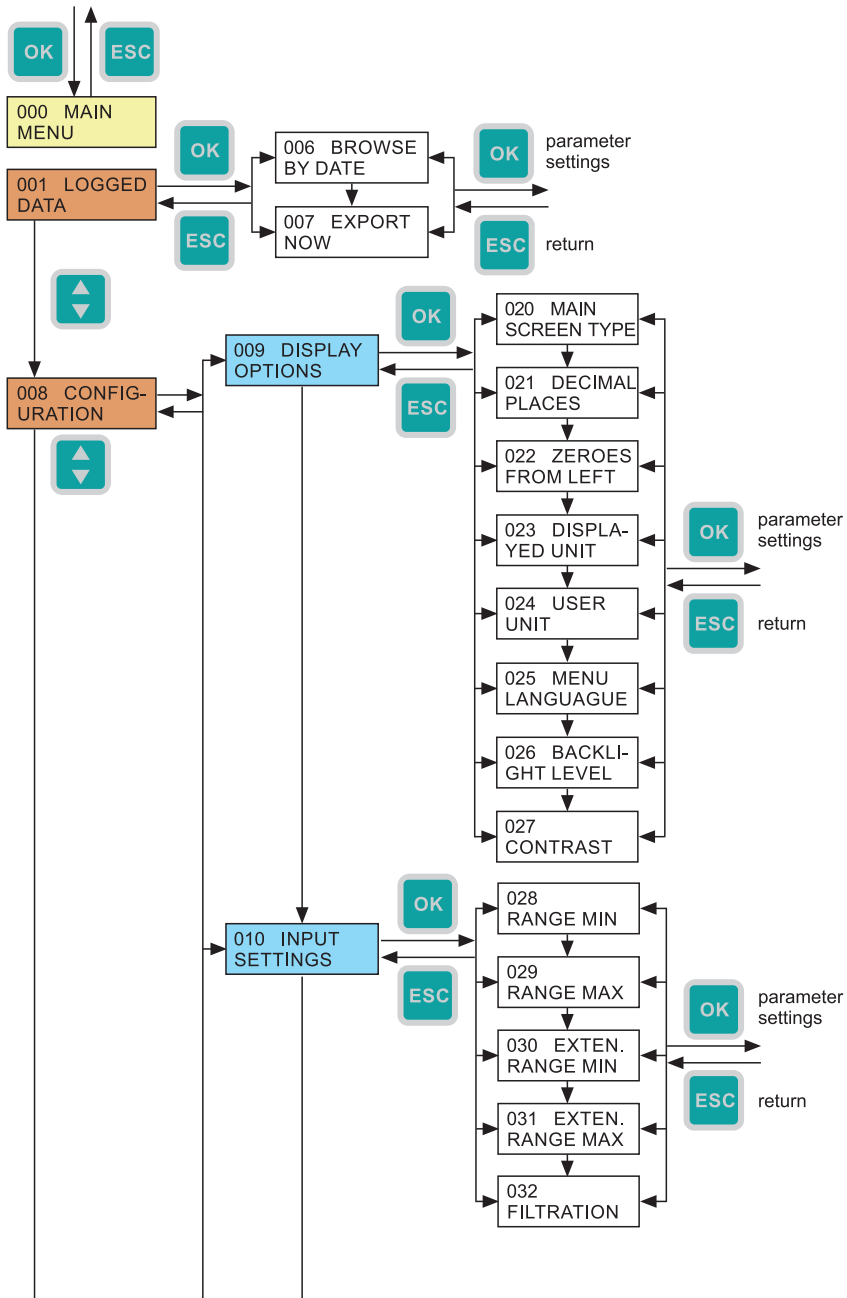

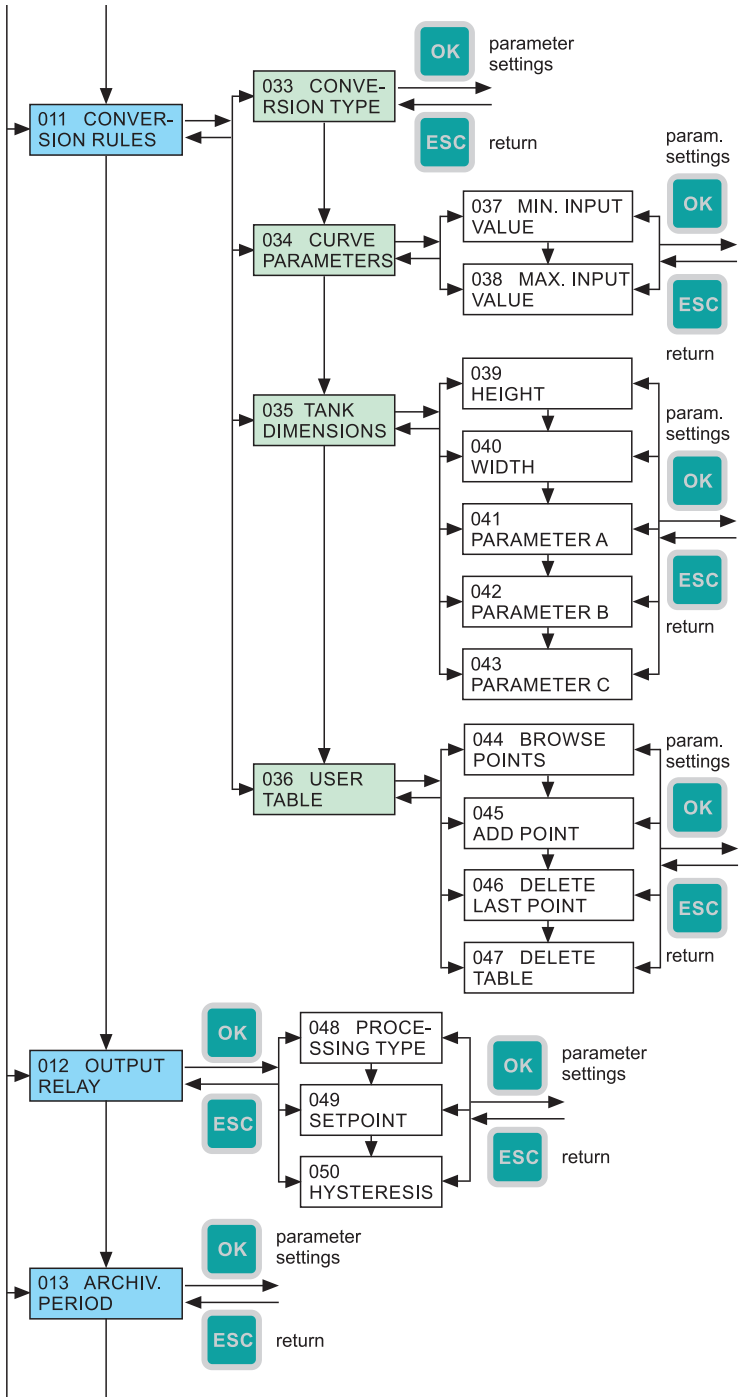

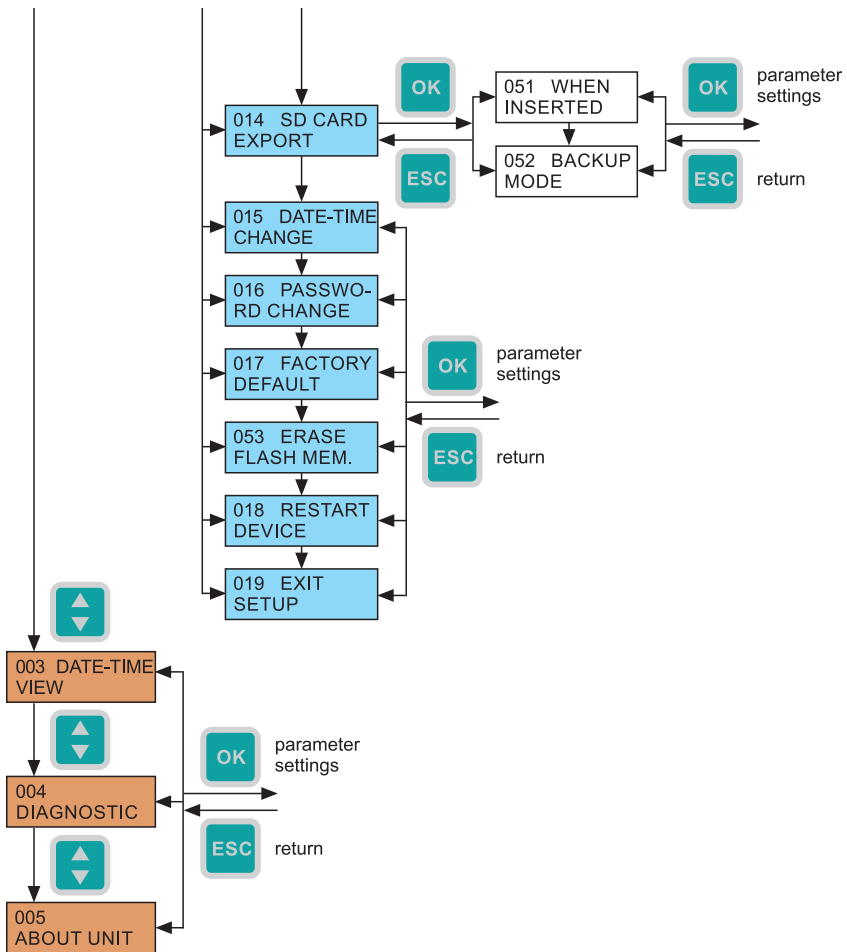

10. FUNCTIONS OF THE EQUIPMENT

10.1. DESCRIPTION OF THE FRONT PANEL

PCU-100-D

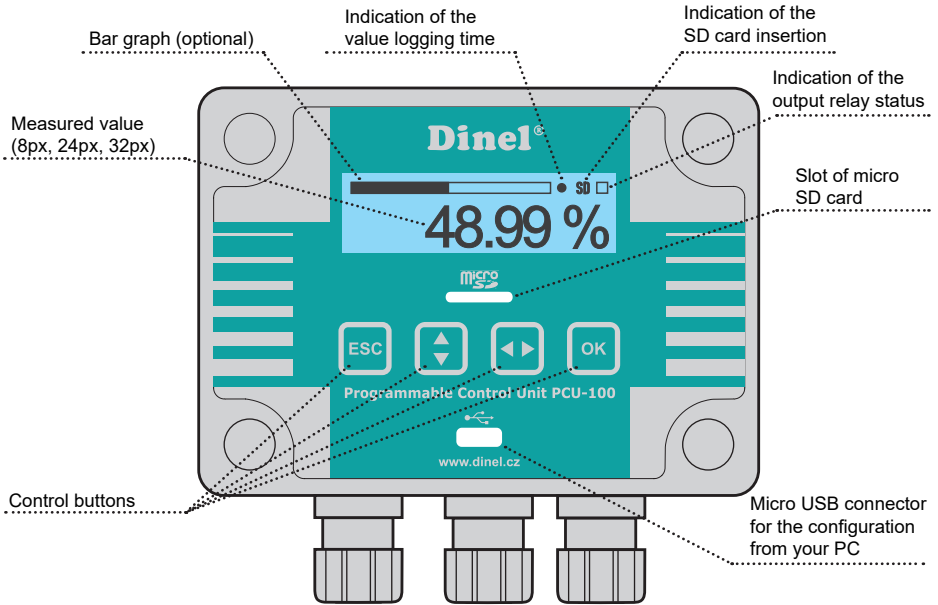

PCU-100-L

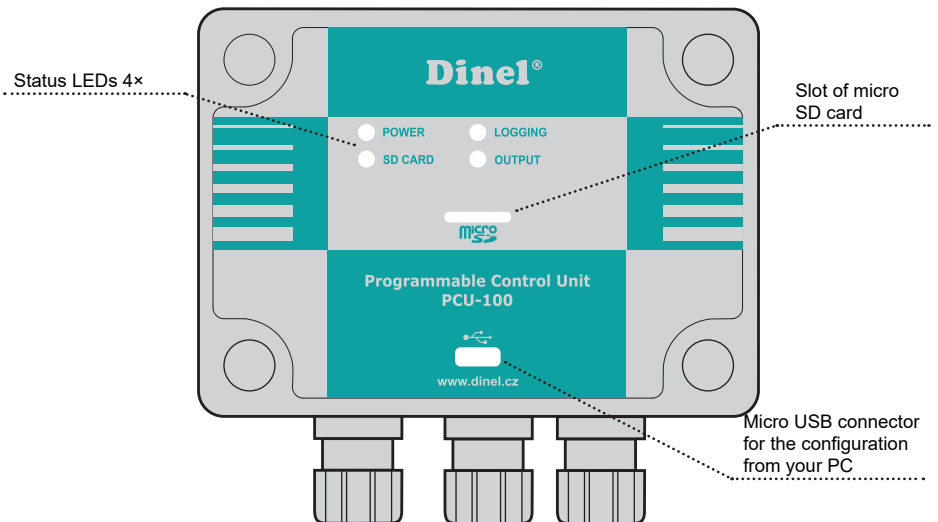

10.2. SIGNALLING FUNCTIONS

PCU-100-L

LED POWER:

- Flashing: Unit in operation
- Lit: Initialization

LED LOGGING:

- Indication of the instant of logging data into memory (blinking for 500ms)

LED SD CARD:

- Flashing: Data entry to the SD card
- Lit: SD card inserted
- Information on the threshold configuration of individual relays

LED OUTPUT:

- Status of the output relay

PCU-100-D - Error Values (instead of the measured value)

- + N/A Input value is below the minimum level of the extended range.
- - N/A Input value is above maximum of the extended range.
- N/A Entry error or inadmissible conversion parameters
- +Over Value to display greater than 999999
- -Over The Value to display less than -99999.9

10.3. EXPORT OF DATA

- The logged data from the internal memory of the unit can be exported to a micro SD card for additional processing. For access to the slot for memory card insertion, it is necessary to withdraw first the transparent polycarbonate housing of the front panel that is held in place by 4 plastic screws (see chapter Mechanical Assembly).
- In the default configuration export of data to the SD card will take place immediately after inserting a memory card into your device. This behaviour is possible to modify in the configuration and run data export manually through the menu (see chapter 9.5.2 Automatic export of data on the SD card) or configuration application of the unit.
- The unit can also be configured for automatic export of the data to the SD card, whether periodically or when the internal memory is full (see chapter 9.5.3 Configuration of the backup mode). For the functioning of these automatic backups, it is necessary to keep the memory card inserted in the unit. After the completion of the work with the data, it is necessary to return the transparent polycarbonate housing of the front panel back on its place and properly tighten the screws to achieve full coverage.



Be extremely careful when placing the cover in place. It is not possible to settle the front cover arbitrarily, there are located protrusions on the bottom of the housing and on the body of the boxes. At bad settlement, these protrusions may prevent the full engagement of the seal and the achievement of full coverage.

- The data are stored on a memory card in CSV format. Path to the stored file will be as follows: /PCU-100/SNXXXXXX/DATA_YYY.CSV, where XXXXXX is the serial number of the unit and YYY sequence number of the file. Up to 999 files with exported data can be saved for each unit of the PCU-100 without overwriting the previous file.

 The delimiter in a CSV file is dependent on the selected menu language. EN: “,” CZ: “;”

- **Menu: EXPORT NOW (ID 007)**



10.4. DISPLAYING FUNCTIONS OF THE USER MENU

The function of the user menu in the version with the display (PCU-100-D) are not restricted only to the configuration of the unit. Additional functions for data management and diagnostics are described in this chapter.

10.4.1. Browsing through the data saved in the FLASH memory

This unit enables displaying the values stored in the internal FLASH memory. First, date is specified by means of the interface, to which the user requires to view the values. The unit then searches for a saved location closest to this date and displays the value. Then, the user can move in memory from this position in the time forward or backward by pressing the appropriate button. The search for the requested date may be any time repeated.

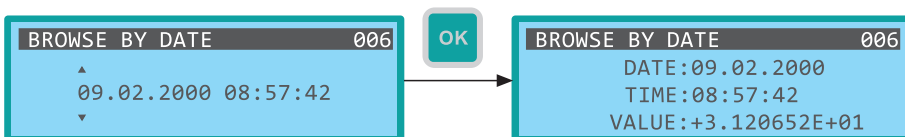

- **Menu: BROWSE BY DATE (ID 006)**

Time Specification

- **[↔] - Movement between the characters [↑] - Increase of the marked digit value**

Move to the requested position

- **[↔] - A shift by a position back, [↑] - A shift by a position forward**



10.4.2. Display of the real date and time of the unit

Even without entering the password for the unit configuration, it is possible to display the current real date and time of the unit on the screen. Its change is possible only in the configuration (see chapter 9.6.1).

- **Menu: DATE-TIME VIEW (ID 003)**



10.4.3. The diagnostic options

Particularly, when installing the unit into operation and its initial configuration, the information displayed on the physical value input values and the corresponding user value according to the current configuration can be useful at the same time. Therefore, the user has available the screen, where there is also displayed the input value in the appropriate units and its conversion into the percentage value and the resulting user value for viewing and archiving. All values are displayed in real time without filtration (dumping).



The value of the input magnitude in percentage is important for all user conversion types. The correct configuration of the input range is therefore crucial for the correct function of the conversion.

- **Menu: DIAGNOSTIC (ID 004)**



For determination of the basic production data about the unit, the specified screen can be used. This screen shows the unit type, its serial number and the firmware version.

- **Menu: ABOUT UNIT (ID 005)**



11. ORDER CODE

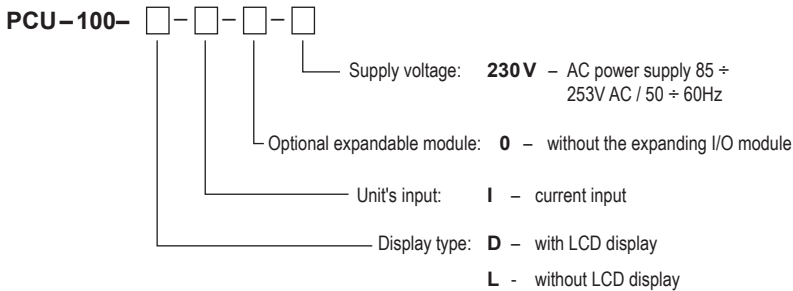

12. CORRECT SPECIFICATION EXAMPLES

PCU-100-D-I-0-230V

(D) version with display; (I) current entry; (0) without the expanding I/O module; (230V) power supply voltage 230 V.

13. SAFETY, PROTECTIONS, COMPATIBILITY AND EXPLOSION PROOF

The PCU-100 unit is protected by an internal blow fuse. The current unit input is protected against short circuit.

The electrical equipment of the protection class II. Electrical safety according to EN 61010-1.

The electromagnetic compatibility is ensured by compliance with standards EN 55011, EN 61326-1, EN 61000-3-2, EN 61000-3-2, -3-3, -4-2 (4 kV/8 kV), -4-3 (10 V/m), -4-4 (1 kV /2 kV), -4-5 (2 kV), -4-6 (10 V) and -4-11.

14. USE, MANIPULATION AND MAINTENANCE

The operator can do the control of the unit function (displayed data) and of the device operator through the MENU that is not protected by password and, also, copy the archived data to the Micro SD card.

The equipment contains the user-replaceable battery for backup of the real time circuit in the bracket on the bottom side of the unit's front panel. For the access to it, it is necessary to remove the front panel (see section 8. Electrical connection). Then, we move the battery out of the bracket to the side and replace it with a new one. The battery must be replaced if the unit is not able to store the configured real time without a connected power supply.



Battery Type: coin cell CR2032, 3V, operating temperature range at least -25 to 70 °C.

The maintenance of the equipment consists of removing dust from the surface of the device and checking of the box integrity. In the case of detection of any visible defects, immediately inform the manufacturer or reseller of the device. The spaces, in which you can use the power unit are determined in the Article 2 of these technical specifications.



Any changes or interventions without the permission of the manufacturer are forbidden to be performed on the PCU-100. Any repairs must be carried out only at the manufacturer or by his authorized service organization.

The assembly, installation, commissioning, operation and maintenance of the PCU-100 must be carried out in accordance with this manual and must comply with the provisions of the standards in force for the installation of electrical equipment.

15. GENERAL, CONDITIONS AND WARRANTY

The manufacturer guarantees from the supply that this product will have established properties given in the technical conditions for a period of 3 years.

The manufacturer is responsible for the faults that have been identified during the warranty period and were claimed in writing.

The warranty does not apply to defects resulting from improper handling or failure to comply with the technical specifications.

The warranty shall expire if the customer or a third party carries out changes or modifications of the product, if the product is mechanically or chemically damaged, or if the production number is not legible.

For the application of a claim, it is necessary to submit the certificate of warranty.

In the event of justified complaint, we repair the defective product, or replace it with a new one. In both cases, the warranty period shall be extended by the time of the repair.

16. MARKING OF LABELS

Data on the plate of the unit of **PCU-100** series

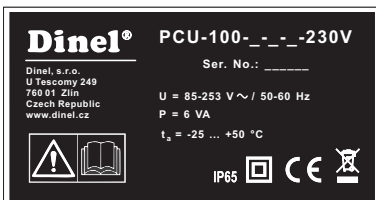

The manufacturer's mark: Dinel® logo

Contact: Dinel, s.r.o., U Tescomy 249, 760 01 Zlín, Czech Republic, www.dinel.cz

Unit type: PCU-100-__-__-230V

Serial number of the product: Ser. No.: _____ - (from the left: production year, serial production number)

Supply voltage: U = 85 - 253 V / 50 - 60 Hz

Rated power consumption: 6 VA

Operating temperature range: $t_a = -25$ to $+50$ °C

Degree of protection: IP65

The character of double insulation (device of protection class II):

The conformity mark: **CE**

The symbol for the return of WEEE -:



Plate size 50 × 26 mm, the size displayed does not correspond to reality.

17. TECHNICAL SPECIFICATIONS

| BASIC TECHNICAL DATA | |
|-----------------------------|---|
| Supply voltage | 85 - 253 V AC |
| Rated power consumption | 6 VA |
| Outlet | 1 × SSR relay, max. 250 V AC / 100 mA |
| Inlet | active current loop (4 - 20 mA) power supply 24 V +/- 10%, serial impedance <110 Ω |
| Measuring accuracy | +/- 0,1% |
| Display type | graphical LCD 132×32px with backlight |
| Control | Foil keypad - 4 buttons, PC program - connect the micro USB |
| Internal memory size | min. 500,000 records |
| Archiving Period | user adjustable (1 sec to 8 hours) |
| The menu language | Czech, English |
| Dimensions | 110×80×65 mm |
| Weight | 320g |
| Housing - material | ABS/PC |
| Protection class | IP 65 |
| Ambient working temperature | -25°C to +50°C |

| ELECTRICAL PARAMETERS OF THE RELAY OUTPUT | |
|---|-----------------------|
| Maximum switched voltage | ±50 V DC / 230 V AC |
| Max. switched current | ±120 mA DC / 80 mA AC |
| Maximum resistance is in the closed state | 30 Ω |
| The maximum current flowing through the opened contacts | 1 μA (U = 100 V) |
| Insulating Voltage | 5 kV AC (RMS) |

18. PACKING, SHIPPING AND STORAGE

The PCU-100 is wrapped in a polyethylene bag and the whole consignment is placed in a card box. In the carton box, appropriate padding is used to prevent mechanical damage during transport.

Remove the device from the packaging just before its use, you may avoid possible damage.

The transport to the customer is realized by means of a forwarding company. After a prior agreement, personal taking of the ordered goods from headquarters is also possible. When taking over, please make sure that the consignment is complete and corresponds to the extent of the order, and that no damage occurred to the equipment when transporting. Do not use a device obviously damaged during transport, but contact the manufacturer in order to address the situation.

If the device is to be transported further, then only wrapped in the original packaging and protected against shocks and weather conditions.

Store the device in the original packaging in dry areas covered from the weather conditions, with a moisture up to 85 % without any effects of Chemically active substances. Storage temperature range is -10 °C to +50 °C.

Dinel[®]

industrial electronics

Dinel, s.r.o.
U Tescomy 249
760 01 Zlín
Czech Republic

Phone: +420 577 002 002
Fax: +420 577 002 007
E-mail: obchod@dinel.cz

www.dinel.cz

The current version of the manual can be found on www.dinel.cz

Version:11/2018

