



CAPACITIVE LEVEL METERS CLM-36

TABLE OF CONTENTS

1. Measuring principle	3
2. Range of applications	3
3. Features of variants	4
4. Dimensions drawings	5
5. Influence of the tank shape on a linearity of measurement	7
6. Installation and putting into operation	8
7. Installation	8
8. Electrical connection	11
9. Preparing of level meter for measuring	12
10. Setting	13
11. Use, manipulation and maintenance	15
12. Order code	16
13. Correct specification examples	16
14. Accessories	16
15. Safety, protections, compatibility and explosion proof	17
16. Marking of labels	18
17. Specification	20
18. Table of relative permittivity	24

USED SYMBOLS

To ensure maximum safety of control processes, we have defined the following safety instructions and information. Each instruction is labeled with the appropriate pictogram.



Alert, warning, danger

This symbol informs you about particularly important instructions for installation and operation of equipment or dangerous situations that may occur during the installation and operation. Not observing these instructions may cause disturbance, damage or destruction of equipment or may cause injury.



Information

This symbol indicates particularly important characteristics of the device.



Note

This symbol indicates helpful additional information.

all types

Valid for:

In the border are the types CLM, for which is intended the chapter.

SAFETY



All operations described in this instruction manual have to be carried out only by trained personnel or an accredited person. Warranty and post warranty service must be exclusively carried out by the manufacturer.

Improper use, installation or set-up of the level meter can result in crashes in the application (overflowing of the tank or damage of system components).

The manufacturer is not responsible for improper use, losses of work caused by either direct or indirect damage, and for expenses incurred during installation or use of the level meter.

1. MEASURING PRINCIPLE

Capacitive level meters CLM® are designed for continuous level measurement of liquids, powders and bulk-solid materials in vessels, tanks, sumps, containers, silos, etc. CLM consists of the stainless steel housing with electronic module and the measuring electrode. Type of measuring electrode is defined by kind of use and type of measured media. The electronic part converts the capacity into the current signal (4 ... 20 mA) or voltage signal (0 ... 10 V). Sensitivity (SPAN) and initial capacity compensation (ZERO) can be fluently set. CLMs are offered in version (N) for non-hazardous environments or (Xi) version to explosive areas up to zone 0 or zone 20, high temperature performance and several types of process coupling are also available.

2. RANGE OF APPLICATIONS

Capacitive level meters are suitable for continuous level measurement of liquid and bulk-solid materials. CLMs are resistant to any changes in the atmosphere above the surface (vacuum, pressure, vapours, dust). It is also partially resistant to the formation of foam on the surface.

3. FEATURES OF VARIANTS

- CLM-36_-10** **With uncoated rod electrode** for level measurement of non-conductive liquids (oils, diesel, petrol) and powder or bulk-solid materials (flour, sand, cement, plastic granulates, etc.). Max. length 5 m.
- CLM-36_-11** **With fully (PFA) coated rod electrode** for level measurement of water and conductive liquids incl. wasted liquids in metallic vessels, concrete sumps, reservoirs, etc., better behaviour against aggressive media, lower adhesion to some complicated media, chemical resistance. Max. length 3 m.
- CLM-36_-12** **With fully (FEP) coated rod electrode** for level measurement of water and conductive liquids incl. wasted liquids in metallic vessels, concrete sumps, reservoirs, etc., better behaviour against aggressive media, lower adhesion to some complicated media, chemical resistance. Max. length 3 m.
- CLM-36_-20** **With uncoated rod electrode and reference tube** for accurate level measurement of clean non-conductive liquids (oils, diesel, petrol). By means of reference tube the output signal does not depend on the dimensions and shapes of a vessel. Max. length 3 m.
- CLM-36_-22** **With fully FEP coated rod electrode and reference tube** for accurate level measurement of conductive liquids. Main use is for measurement in plastic vessels or tanks. Impossible to use for waste and high viscosity liquids and bulk-solid materials. Max. length 3 m.
- CLM-36_-30** **With uncoated stainless steel rope electrode and uncoated weight** for level measurement of bulk-solid materials (grains, sand, flour, cement, etc.). Max. length 20 m.
- CLM-36_-31** **With uncoated stainless steel rope electrode and coated dynamic anchorage** for level measurement of bulk-solid materials in higher silos. Max. length 20 m.
- CLM-36_-32** **With fully coated rope electrode and coated weight** (rope insulation FEP, weight insulation PTFE), for level measurement of electrically conductive and non-conductive liquids. Max. length 20 m.
- CLM-36_-40** **With two coated electrodes** (rope insulation FEP, head fully PTFE), for level measurement of aggressive liquids. Performance for non-explosive areas only. Max. length 2 m.

4. DIMENSIONS DRAWINGS

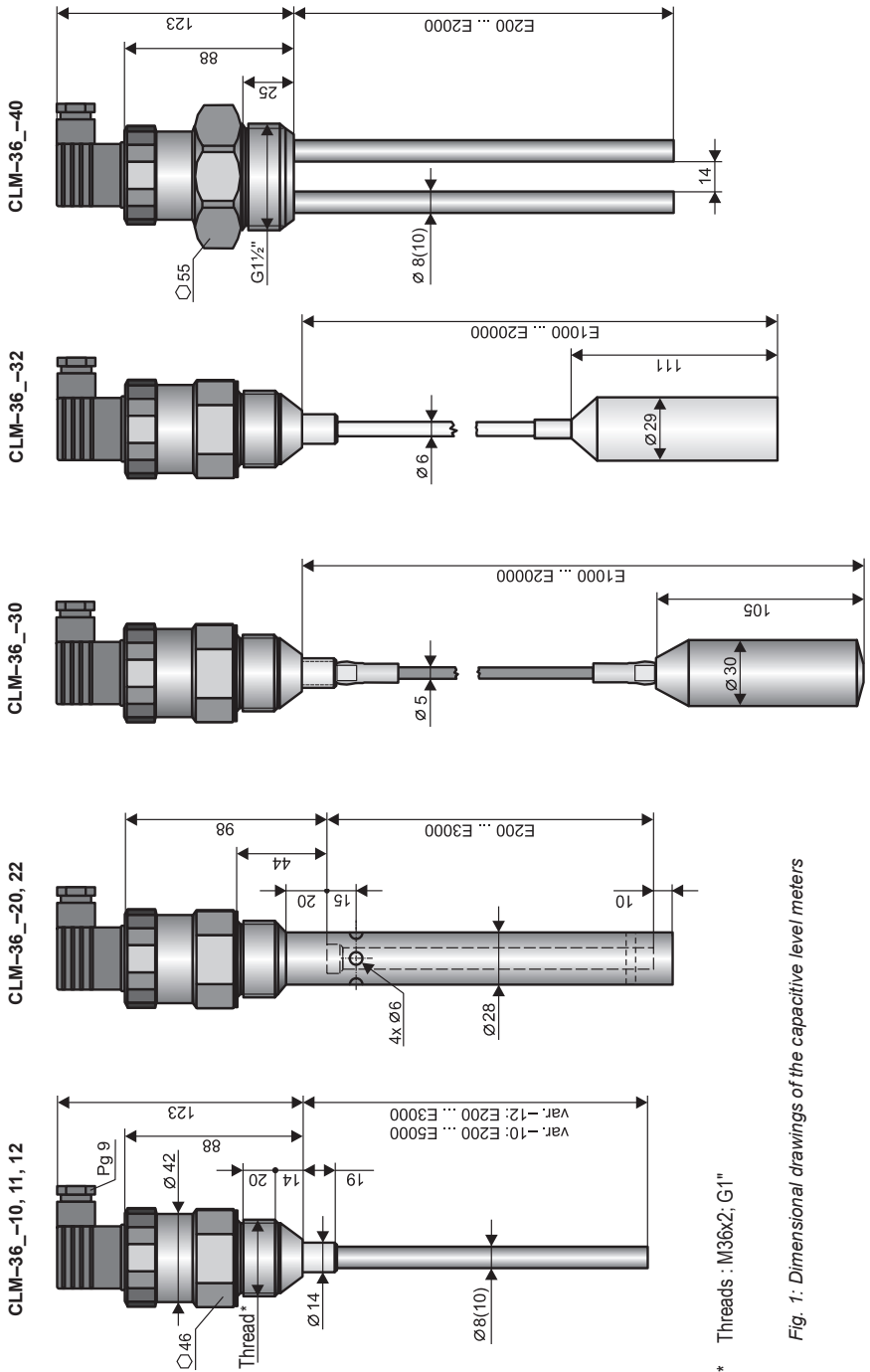

* Threads : M36x2; G1"

Fig. 1: Dimensional drawings of the capacitive level meters

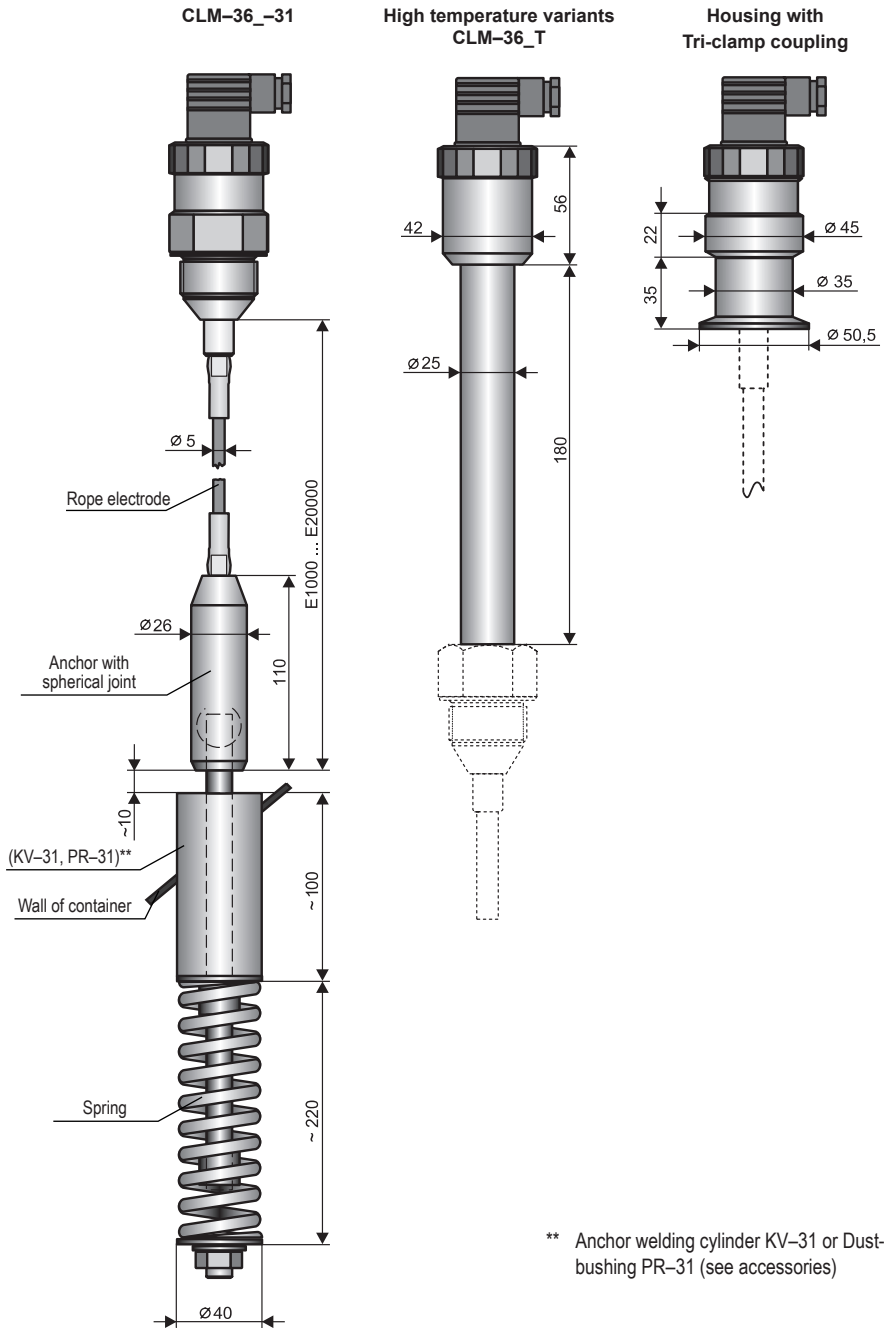

** Anchor welding cylinder KV-31 or Dust-tight bushing PR-31 (see accessories)

Fig. 2: Dimensional drawings of the capacitive level meters

5. INFLUENCE OF THE TANK SHAPE ON A LINEARITY OF MEASUREMENT

- In a curved tanks (most frequently horizontal cylinder) capacity change during measuring of electrically non-conductive material is non-linear.

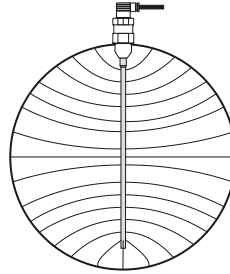

CLM-36_-10, 11, 12

CLM-36_-30, 31, 32

- Linearity is done by reference tube (CLM-36_-20, 22), or by reference electrode (CLM-36_-40).

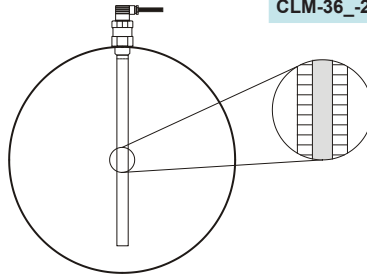

CLM-36_-20, 22, 40

- In the tank with straight wall (for example vertical cylinder) and with the sensor placed parallelly with the wall capacity change is linear.

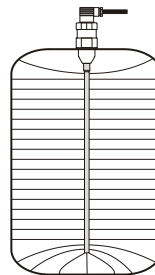

all types

- For sensors with two electrodes (in the tank with straight or curved wall) is the capacity change linear.

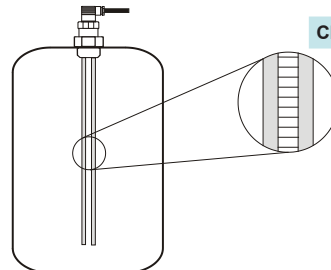

CLM-36_-40

Fig. 3: Influence of the tank shape on a linearity of measurement

6. INSTALLATION AND PUTTING INTO OPERATION

Please follow next 4 steps:

- **INSTALLATION**
- **ELECTRICAL CONNECTION**
- **PREPARING OF LEVEL METER FOR MEASURING**
- **SETTING**

7. INSTALLATION

BASIC INFORMATION

Level meters with coated electrode have protection cover at the end of electrode, which is necessary take down before mounting.

Level meters mount in vertical position to upper lid of tank or reservoir by steel welding flange ON-36x2 (steel 11375), stainless steel welding flange NN-36x2 (stainless steel 1.4301), fixing nut UM-36x2 (stainless steel 1.4301) or Clamp flange.

For mounting level meter to the metal tank or reservoir is not necessary to ground housing again.

In case of installation in concrete sumps or silos it is properly to install level meter at metallic auxiliary construction (console, lid, etc.) and then connect with metal all the time submerged object, eventually with steel armouring.

For measuring of material in plastic and glass vessels by level meter without reference tube is necessary to connect grounding screw at housing with auxiliary electrode which is fixed by the appropriate method to the outer casing of vessels (or at inner wall). Material of auxiliary electrode is necessary to choose with consideration to the working environment and properties of measured material.

METAL AND NON-METAL VESSELS

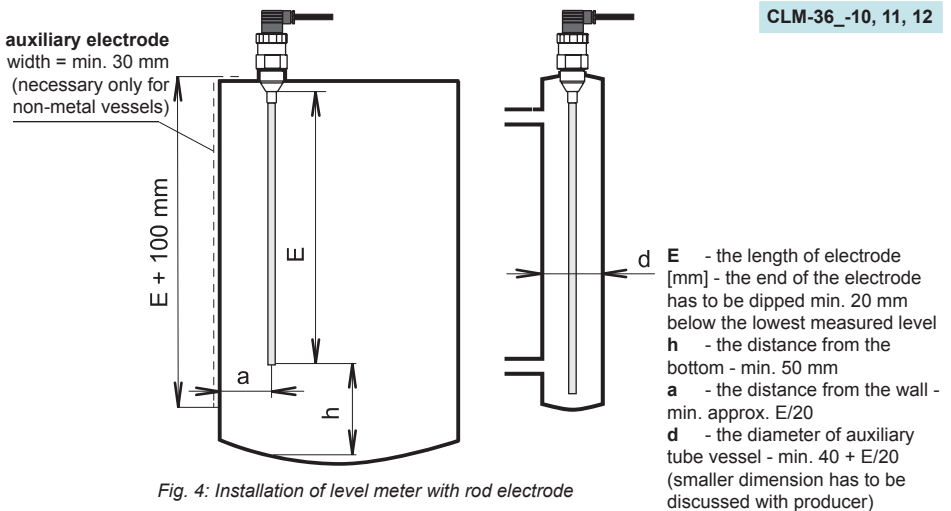
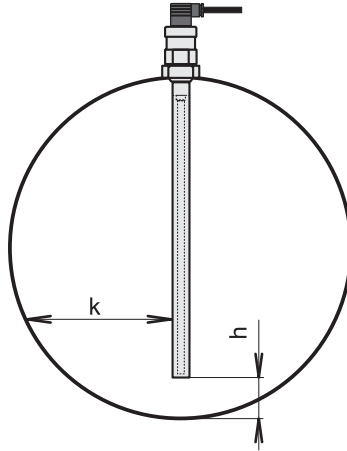

Fig. 4: Installation of level meter with rod electrode

VARIANTS WITH REFERENCE TUBE

CLM-36_-20, 22



h - the distance from the bottom
- min. 50 mm with respect on possibility of presence of heavy fraction (water) in oil products
k - the distance from the wall - optional

Fig. 5: Installation of level meter with reference tube

DEEP VESSELS, CONTAINERS AND SILOS

CLM-36_-30, 32

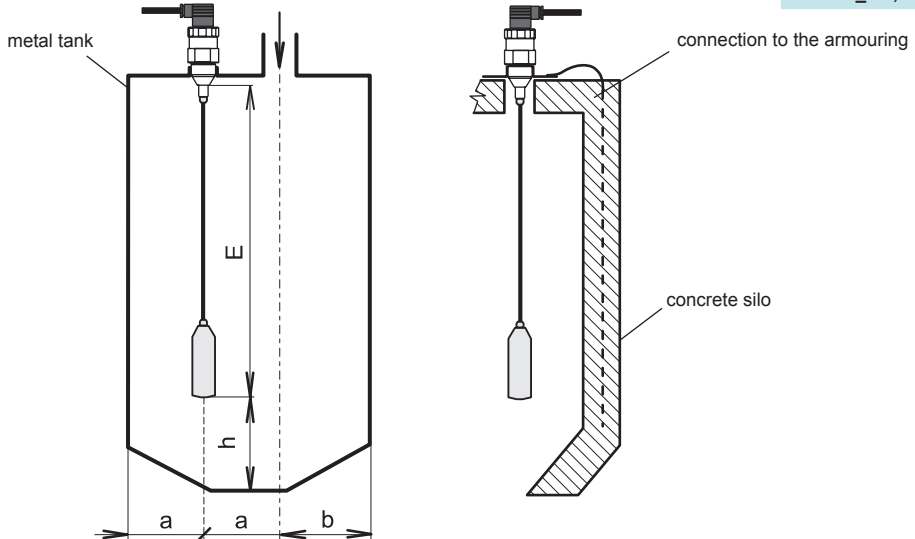

- E** – The length of electrode - the lower end of the electrode has to be dipped - min. 20 mm below the lowest measured level
- h** – The distance from the bottom - min. 100 mm
- a** – The distance from the wall - at least $E/20$, as far as possible from the walls, to the middle between the wall and the vertical inlet

Fig. 6: Installation of level meter with rope electrode

ROPE ELECTRODE WITH ANCHOR

CLM-36_-31

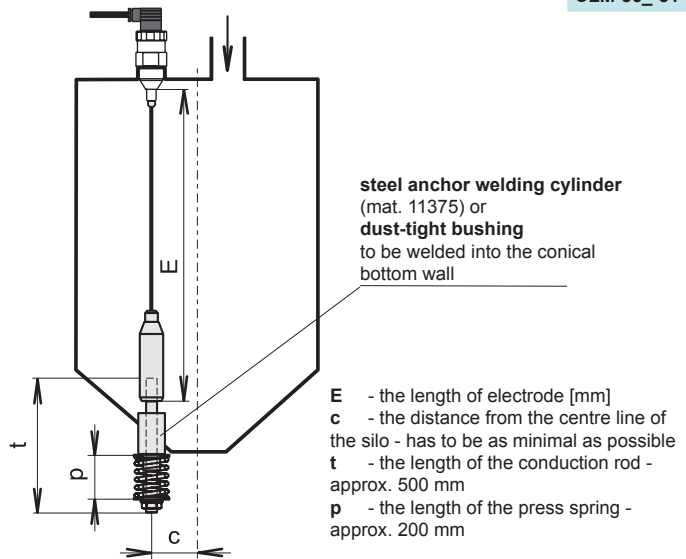

Fig. 7: Installation of rope electrode with anchor

AGGRESSIVE LIQUIDS, NON-METALLIC VESSELS

CLM-36N_-40

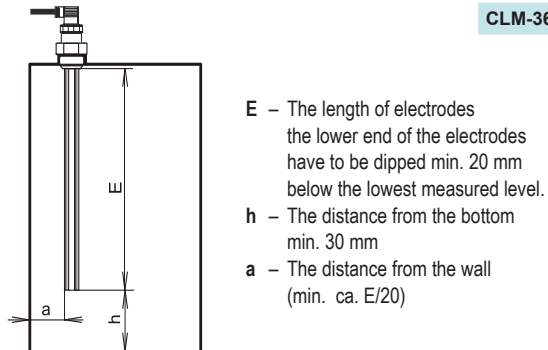

Fig. 8: Installation of level meter with reference electrode



For correct function of level meter type CLM-36N_-40 is necessary to ensure stable impedance between the measured medium and the ground. This can be provided by:

- 1) The medium is isolated from all devices that may cause temporary grounding of the medium (pumps, valves, connection with the grounded tank by flowing medium).
- 2) If the first option is not possible, it is necessary to ground the medium permanently.

8. ELECTRICAL CONNECTION

The level meter is designed to be connected to supply unit or to controller through a cable with the outer diameter of $6 \div 8$ mm (recommended cross-section of cores $0.5 \div 0.75$ mm²) by means of connector which is standard part of CLM level meter. The scheme and the inside of the connector

Procedure to connect the cable to the level meter:

1. Unscrew connector from the body of the level meter using a suitable screwdriver.
2. Use a flat screwdriver to remove the inner part of the connector (screwdriver into the gap marked by arrow).
3. Unscrew the cable gland and put the cable inside.
4. Connect the cable wires to the screw terminals as shown in Fig. 10 (current output 4-20 mA) or Fig. 12 (voltage output 0-10 V). Tighten the terminals firmly.
5. Push the terminals back into the connector so that the terminal no. 3 is oriented toward the cable entry. Tighten the cable gland.
6. Check the seal on the connector and connect the connector back to the body of the sensor.

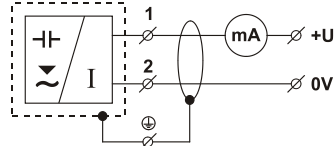

Fig. 9: Connection scheme with current output

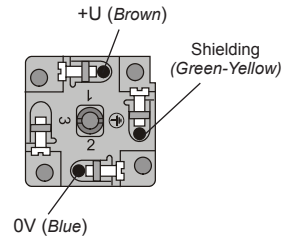

Fig. 10: Connection scheme with current output

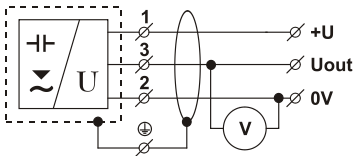

Fig. 11: Connection scheme with voltage output

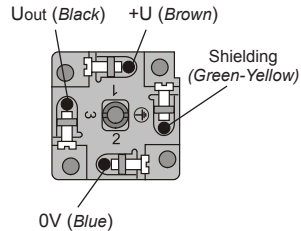

Fig. 12: Connection scheme with voltage output



Electrical connection must be done in de-energized state!



The voltage source should be preferably realized as a stabilized power supply unit with safe voltage from 18 to 36 V DC ($18 \div 30$ V DC at version Xi(XiT)), which can be a part of the evaluation or display device.

In case of strong electromagnetic interferences (EMI), parallel cable ducting with power lines, or when cable length exceeds 30 m we recommended to use shielded cable.

9. PREPARING OF LEVEL METER FOR MEASURING

PREPARING OF LEVEL METER

1. For access to the adjustment elements disconnect a connector and unscrew a nut (attention for inside connecting wires). Connect the connector again.
2. Connect the level meter to the supply unit through milliammeter (controller, etc.).
3. Set the trimmer¹⁾ **20 mA** into the basic position (this position is set by producer):
 - a) Turn the trimmer totally right (clockwise).
 - b) Turn the trimmer back about 3 turns left (anti clockwise).

ADJUSTMENT ELEMENTS OF LEVEL METER

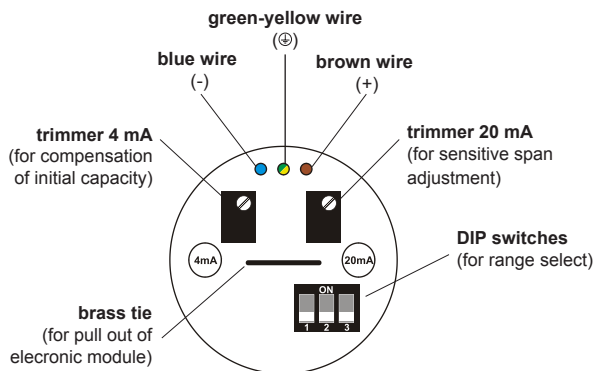

Fig. 13: The top view on the internal electronic module with current output (variant -I)

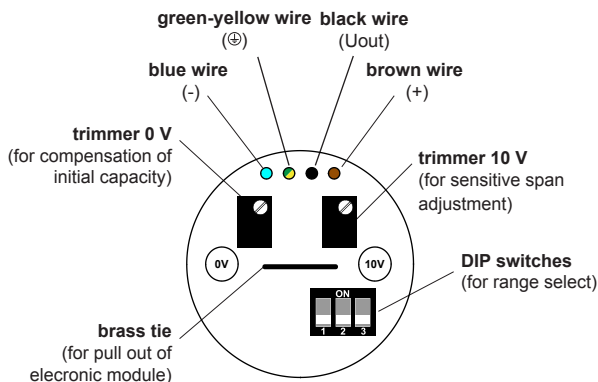

Fig. 14: The top view on the internal electronic module with voltage output (variant -U)

1) The trimmers are without backstops - approx. 15 turns.

10. SETTING

CURRENT OUTPUT 4 ... 20 mA

1. Empty the tank to the minimum level.
2. Set the DIP switches on the CLM to range³⁾ No. 2 (250 pF).
3. By a screwdriver turn the trimmer 4 mA and set the quiescent current of the level meter to 4 mA. Turning rightwards (clockwise) increases the current, turning leftwards decreases the current. When it is impossible to set required current to 4 mA, then switch DIP switches to the nearest higher range and set up the current 4 mA at that range.
4. Fill the tank to the maximum level. When it is impossible fill the tank to the maximum known (or checkable) level. For the next settings calculate the output current using the next formula:

$$I_{out} = 4 + (0,16 \times \text{level in \%}) \text{ [mA]}$$

5. If the output current is less than 20 mA (or the calculated value of I_{out}), set the DIP switch to the lowest range No. 1. and continue to step 7. When the output current exceeds 20 mA, continue on step 6.
6. Set the DIP switches step by step to higher ranges till the current is greater than 20 mA (or calculated value of I_{out}), then the current e.g. 21 mA⁴⁾ flows through the level meter. Trimmer 20 mA is still in basic position.
7. Then set the current of CLM by **trimmer 20 mA** onto 20 mA (or to the calculated value of I_{out} - see above).
8. To reach a maximum accuracy is useful to check the setting of 4 mA again (compensation of initial capacity - quiescent current).

VOLTAGE OUTPUT 0 ... 10 V

1. Empty tank to the minimum level.
2. By DIP switches on level meter set range³⁾ No. 2 (250 pF).
3. By a screwdriver turn the trimmer 0 V and set the quiescent voltage of the level meter to 4 mA. Turning rightwards (clockwise) increases the voltage, turning leftwards decreases the voltage. When it is impossible to set required voltage to 0 V, then switch DIP switches to the nearest higher range and set up the voltage 0 V at that range.
4. Fill the tank to the maximum level. When it is impossible fill the tank to the maximum known (or checkable) level. For the next settings calculate the output voltage using the next formula:

$$U_{out} = 0,1 \times \text{level in \%} \text{ [V]}$$

5. If the output voltage is less than 10 V (or the calculated value of I_{out}), set the DIP switch to the lowest range No. 1. and continue to step 7. When the output voltage exceeds 10 V, continue on step 6.









2) Sensitivity - minimal capacity change of electrode to reach output range 4 ÷ 20 mA or 0 ÷ 10 V.

3) Range = capacity of housing + activated electrode to reach output range 4 ÷ 20 mA or 0 ÷ 10 V.
(For example.: uncoated electrode 1000 mm immersion in fuel: 20 pF + 30 pF,
coated electrode 1000 mm immersion in water: 20 pF + 500 pF)

4) In case of short of electrode on housing or setting of a very sensitive range can caused to current restriction of level meter on value max. 30 mA.

Set the DIP switches step by step to higher ranges till the voltage is greater then 10 V (or calculated value of I_{out}), then the voltage e.g. 11 V⁴⁾ flows through the level meter. Trimmer 10 V is still in basic position.

7. Then set the voltage of CLM by **trimmer 10 V** onto 10 V (or to the calculated value of I_{out} - see above).
8. To reach a maximum accuracy is useful to check the setting of 0 V again (compensation of initial capacity - quiescent voltage).

No.	Sensitivity ²⁾ (S)	Range ³⁾ (R)	Position of DIP switch
1 ¹⁾	20 pF	70 pF	
2	30 pF	250 pF	
3	50 pF	600 pF	
4	100 pF	1 200 pF	
5	150 pF	3 000 pF	
6	300 pF	7 000 pF	
7	500 pF	18 000 pF	
8	1 000 pF	36 000 pF	

1) Range No. 1 (70 pF) is very sensitive and we recommend to use it only at level meters with short electrode (approx. to 500 mm) and measured media with low permittivity.

Tab. 1: Table of ranges

Medium Type	Sand, grains		Cement		Flour	
	1 m	5 m	1 m	5 m	1 m	5 m
10	2	3	2	4	1	3
12	2	3	2	4	1	3
30	2	3	2	4	1	3

Medium Type	Water		Benzine, petroleum, diesel, oil	
	1 m	2 m	1 m	2 m
10	-	-	1	2
12	3	4	1	2
20	-	-	2	3
22	3	4	2	3
32	3	4	1	2

Tab. 2: Tables of recommended ranges depending on the medium and the type of level meter

Note: Types 10, 12, 30, 31, 32 in distance 250 mm from conducting wall. Showned ranges are orientation. Exact range for existing configuration electrode / tank must be set directly in application on meared medium.

11. USE, MANIPULATION AND MAINTENANCE

The level meter does not require any personnel for its operation. Follow-up displaying device is used to inform the technological entity operating personnel on the measured substance level height during the operation.

MAINTAINCE OF LEVEL METER

Maintenance of this equipment consists in verification of integrity of the level meter and of the supply cable. Depending on the character of the substance measured, we recommend to verify at least once per year the clarity of the ultrasound transducer emitting field and to clean it, respectively. In case any visible defects are discovered, the manufacturer or reseller of this equipment must be contacted immediately.



The level meter must be installed to prevent tensile overload of the rope electrode.



It is forbidden to perform any modifications or interventions into the CLM-36 level meter without manufacturer's approval. Potential repairs must be carried out by the manufacturer or by a manufacturer authorized service organization only.

Installation, commissioning, operation and maintenance of the CLM-36 level meter has to be carried out in accordance with this instruction manual; the provisions of regulations in force regarding the installation of electrical equipment have to be adhered to.

REPLACEMENT OF DEFECTIVE ELECTRONIC MODULE

In case of detected electronic failure it is possible to replace the electronic module directly in process place of level meter by following procedure:

1. Disconnect connector and unscrew a nut (attention for inside connecting wires).
2. Defective electronic module pick up by pliers onto brass tie and remove by tensile from housing of level meter.
3. Check placing of white seal O-ring in housing and on pressure ring.
4. Repaired or new electronic module return back into housing of level meter and press down by clamping ring (attention that contact pin will be a little open before insertion and contact springs were not pressed under level of electronic casing).
5. Check placing of black seal O-ring on connector.
6. Screw a nut back (attention for inside connecting wires) and connect the connector.

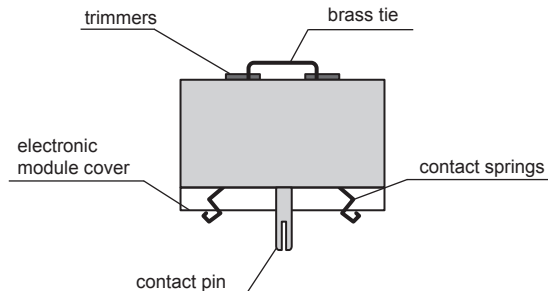

Fig. 15: Side view of the electronic module

12. ORDER CODE

CLM-36 - - E — Length electrode in mm

Output type:

I - current (4 ... 20 mA)

U - voltage (0 ... 10 V)

Process connection:

M - thread M36x2

G - thread G1" (G1½" for CLM-36_-40)

CI - Tri-clamp

Electrode performance:

10 - Uncoated St. steel rod electrode

11 - Fully coated St. steel rod electrode (PFA)

12 - Fully coated St. steel rod electrode (FEP)

20 - Uncoated St. steel rod electrode with reference tube

22 - Coated St. steel rod electrode with reference tube (FEP)

30 - Uncoated St. steel rope electrode and weight (max. 20 m)

31 - Uncoated St. steel rope electrode with anchor (max. 20 m)

32 - Fully coated rope electrode and weight (FEP + PTFE)

40 - Two fully coated St. steel rod electrode (FEP) (max. 2 m)

Performance:

N - normal (for non-explosive areas)

Xi - Explosion proof - intrinsically safe for hazardous (explosive) areas, only with "I" output (except CLM-30_-40)

NT, XiT - High temperature performance

13. CORRECT SPECIFICATION EXAMPLES

CLM-36N-10-G-I E1100

CLM-36NT-12-M-I E1500

CLM-36Xi-20-M-I E900

CLM-36Xi-30-M-I E12000

CLM-36N-32-G-U E6000

CLM-36N-12-CI-I E2000

14. ACCESSORIES

Standard – included in the level meter price

- 1x of seal, other seals are on request (PTFE, Al, etc.)
- 1x connector socket
- 1x screwdriver for adjustment (each 5 pcs)
- Distance element for rods longer than 50 cm (for CLM-36_-40)

Optional (see datasheets "Accessories")

- Connector with protection class IP67 (GAN-DADE 7A) with 5 m cable (current output)
 - Connector with protection class IP67 (GAN-DAAE 7A) with 5 m cable (voltage output)
 - Steel welding flange ON-36x2
 - St. steel welding flange NN-36x2
 - St. steel fixing nut UM-36x2
 - Anchor welding cylinder KV-31 (only CLM-36-31)
 - Dust-tight bushing PR-31 (only CLM-36-31)
-

15. SAFETY, PROTECTIONS, COMPATIBILITY AND EXPLOSION PROOF

Level meter CLM-36 is equipped with protection against electric shock on electrode, reverse polarity, output current overload, short circuit and short time over voltages.

Protection against dangerous contact is secured by low safety voltage that complies with EN 33 2000-4-41.

Electromagnetic compatibility is provided by conformity with standards: EN 55022/B, EN 61326-1, EN 61000-4-2, EN 61000-4-3, EN 61000-4-4, EN 61000-4-5, EN 61000-4-6.

Explosion proof of CLM-36Xi is examined by FTZÚ-AO 210 Ostrava - Radvanice certificate No.: FTZÚ 02 ATEX 0235X.

Special conditions for safe use of variant CLM-36Xi

Equipment is designed to be connected to isolating repeater IRU-420

If other approved apparatus is used, which output parameters comply with above mentioned input parameters it is necessary to have an galvanic separation or in a case of apparatus without galvanic separation (Zener barriers) it is necessary to provide equipotential equalizing between sensor and barrier earthing point.

Design CLM-36Xi can be used in zone 0 or zone 20. With design CLM-36XiT can be only used in zone 0 and zone 20 electrode part and head with electronics can be used only in zone 1 or zone 21. Maximum temperature of electrodes is equal to temperature of measured medium.

When used in zone 0 the present explosive atmosphere of air mixture and gases, vapours or mists must comply with: $-20^{\circ}\text{C} < T_{\text{amb}} < 60^{\circ}\text{C}$ $0,8 \text{ bar} < p < 1,1 \text{ bar}$

16. MARKING OF LABELS

Level meters label data

CLM-36N(T)-_-_-I:

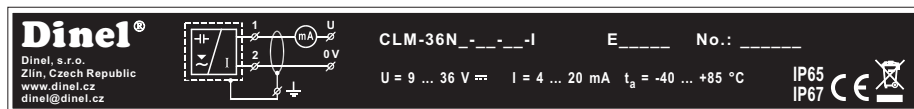

Symbol of producer: logo Dinel®

Contact: Dinel, s.r.o., Zlín, Czech Republic, www.dinel.cz, dinel@dinel.cz

Connection scheme and labelling of wires: U, 0V, GND

Type of level meter: CLM-36-N_-_-_-I, P/N include length of electrode: E in mm

Serial number: Ser. No.: _____ - (from the left: production year, serial production number)

Supply voltage: $U_i = 9 \div 36$ V DC

Output current range: $I = 4 \div 20$ mA

Ambient temperature range: $t_a = -40 \dots +85$ °C

Protection class: IP 65 / IP 67

Compliance mark: **CE**

Electro-waste take-back system mark:

Level meters label data

CLM-36N(T)-_-_-U:

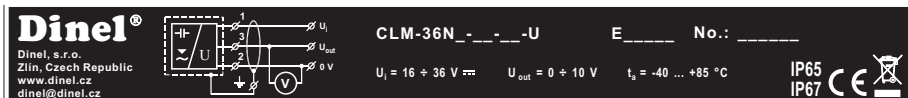

Symbol of producer: logo Dinel®

Contact: Dinel, s.r.o., Zlín, Czech Republic, www.dinel.cz, dinel@dinel.cz

Connection scheme and labelling of wires: U_i , U_{out} , 0V, GND

Type of level meter: CLM-36-N_-_-_-U, P/N include length of electrode: E in mm

Serial number: Ser. No.: _____ - (from the left: production year, serial production number)

Supply voltage: $U_i = 9 \div 36$ V DC

Output voltage range: $U_{out} = 0 \div 10$ V (or $0 \div 5$ V)

Ambient temperature range: $t_a = -40 \dots +85$ °C

Protection class: IP 65 / IP 67

Compliance mark: **CE**

Electro-waste take-back system mark:

Level meters label data

CLM-36Xi:

 <p>Dinel, s.r.o. Zlín Czech Republic www.dinel.cz dinel@dinel.cz</p>		CLM-36Xi-__-__-I	E _____	No.: _____	<p>$U_i = 30V$ $I_i = 132mA$ $P_i = 0,99W$ $C_i = 370nF$ $L_i = 0,9mH$ $t_a = -20 \dots +60 \text{ } ^\circ C$ (zone 0) $t_a = -40 \dots +75 \text{ } ^\circ C$</p>	<p>IP65 IP67</p> 
		<p>II 1 G Ex ia IIB T5 Ga II 1 D Ex ia IIIC T83°C Da</p> <p>FTZÚ 02 ATEX 0235X</p>				

Symbol of producer: logo Dinel®

Contact: Dinel, s.r.o., Zlín, Czech Republic, www.dinel.cz, dinel@dinel.cz

Connection scheme and labelling of wires: U, 0V, GND

Type of level meter: CLM-36-Xi-__-__, P/N include length of electrode: E in mm

Serial number: Ser. No.: _____ - (from the left: production year, serial production number)

Label of non-explosive device: 

Performance: II 1 G Ex ia IIB T5 Ga, II 1 D Ex ia IIIC T83°C Da

No. of authorized person examining control of system quality: 1026

Number of certificate of intrinsically safety: FTZÚ 02 ATEX 0235X

Limit operating parameters: $U_i = 30 V$ DC, $I_i = 132$ mA, $P_i = 0,99$ W, $C_i = 370$ nF,

$L_i = 0,9$ mH

Ambient temperature range: $t_a = -40 \dots +75 \text{ } ^\circ C$, $t_a = -20 \dots +60 \text{ } ^\circ C$ (zone 0)

Protection class: IP 65 / IP 67

Compliance mark: 

Electro-waste take-back system mark: 

Level meters label data

GRLM-70XiT:

 <p>Dinel, s.r.o. Zlín Czech Republic www.dinel.cz dinel@dinel.cz</p>		CLM-36XiT-__-__-I	E _____	No.: _____	<p>$U_i = 30V$ $I_i = 132mA$ $P_i = 0,99W$ $C_i = 370nF$ $L_i = 0,9mH$ $t_a = -20 \dots +60 \text{ } ^\circ C$ (zone 0) $t_a = -40 \dots +75 \text{ } ^\circ C$</p>	<p>IP65 IP67</p> 
		<p>II 1/2 G Ex ia IIB T5 Ga/Gb II 1/2 D Ex ia IIIC T83°C Da/Db</p> <p>FTZÚ 02 ATEX 0235X</p>				

Symbol of producer: logo Dinel®

Contact: Dinel, s.r.o., Zlín, Czech Republic, www.dinel.cz, dinel@dinel.cz

Connection scheme and labelling of wires: U, 0V, GND

Type of level meter: CLM-36-XiT-__-__, P/N include length of electrode: E in mm

Serial number: Ser. No.: _____ - (from the left: production year, serial production number)

Label of non-explosive device: 

Performance: II 1/2 G Ex ia IIB T5 Ga/Gb, II 1/2 D Ex ia IIIC T83°C Da/Db

No. of authorized person examining control of system quality: 1026

Number of certificate of intrinsically safety: FTZÚ 02 ATEX 0235X

Limit operating parameters: $U_i = 30 V$ DC, $I_i = 132$ mA, $P_i = 0,99$ W, $C_i = 370$ nF,

$L_i = 0,9$ mH

Ambient temperature range: $t_a = -40 \dots +75 \text{ } ^\circ C$, $t_a = -20 \dots +60 \text{ } ^\circ C$ (zone 0)

Protection class: IP 65 / IP 67

Compliance mark: 

Electro-waste take-back system mark: 

17. SPECIFICATION

TECHNICAL SPECIFICATION (variants N, NT)		
Supply voltage	CLM-36N(T)-___-I CLM-36N(T)-___-U	9 ... 36 V DC 16 ... 36 V DC
Current output		4 ... 20 mA
Voltage output		0 ... 10 V
Power consumption (off-load)	CLM-36N(T)-___-U	approx. 8mA
Sensitivity ranges		20 ; 30 ; 50 ; 100 ; 150 ; 300 ; 500 ; 1000 pF
Initial capacity regulation ratio		min. 1:2
Nonlinearity		max. 1%
Temperature error		max. 0,05% / K
Voltage error for current and voltage output		max. 0,3 μ A/V and 0,1 mV/V
Internal resistance / Electric strength (Electrode – Housing)		1 M Ω / 250 V AC
Coupling capacity / Electric strength (Housing – Supply leads)		51 nF / 250 V AC
Protection class	Standard Optional (Connector GAN-DADE 7A / DAEE 7A)	IP67 (Housing), IP65 (Connector) IP67
Maximal load (serial) resistance for current output (U = 24 V)		$R_{max} = 750 \Omega$
Minimal load resistance for voltage output		$R_{min} > 1 \text{ k}\Omega$
Maximum tensile strength of the rope electrode		1400 kg
Recommended cable		PVC 2x0,75 mm ² (3x0,5 mm ²)
Weight (exclude electrode)	Version N, Xi Version NT, XiT	approx. 0,5 kg approx. 1 kg

ELECTRICAL PARAMETERS (variants Xi, XiT)	
Supply voltage	9 ... 30 V DC
Max. internal values	$U_i = 30 \text{ V DC}$; $I_i = 132 \text{ mA}$; $P_i = 0,99 \text{ W}$; $C_i = 370 \text{ nF}$; $L_i = 0,9 \text{ mH}$
Internal resistance / Electric strength (Electrode – Housing)	1 M Ω / 250 V AC
Coupling capacity / Electric strength (Housing – Supply leads)	26 nF / 500 V AC
Allowed temperature range in zone 0 (EN 50284)	-20 ... +60°C
Allowed pressure range in zone 0 (EN 50284)	0,08 ... 0,11 MPa

PROCESS CONNECTION		
Type	Size	Marking
Metric thread	M36x2	M
Pipe thread (except CLM-36-40)	G 1"	G
Pipe thread for CLM-36-40)	G 1½"	G
Tri-clamp (standards DN 20)	–	Cl

USED MATERIALS			
Sensor part	Variants	Standard material	Optional (on request)
Housing	All types, except CLM-36_-40	St. Steel W. Nr. 1.4301 (AISI 304)	St. Steel W. Nr. 1.4571 (AISI 316 Ti) St. Steel W. Nr. 2.4858 (Incoloy 825)
	CLM-36_-40	PTFE	-
Insulating bushing	All types, except CLM-36_-40	PTFE	-
	CLM-36_-10, 11, 12, 20, 22, 40 CLM-36_-30, 31 CLM-36_-32	St. Steel W. Nr. 1.4301 (AISI 304) St. Steel W. Nr. 1.4404 (AISI 316 L) Zinc Steel rope	St. Steel W. Nr. 1.4571 (AISI 316 Ti) - -
Electrode coating	CLM-36_-12, 22, 32, 40	FEP	-
	CLM-36_-11	PFA	-
	CLM-36_-31	Polyolefin (modified PE)	PTFE
Weight insulation	CLM-36_-32	PTFE	-
Weight / Anchor mechanism	CLM-36_-30, 31, 32	St. Steel W. Nr. 1.4301 (AISI 304)	-
Reference tube	CLM-36_-20, 22	St. Steel W. Nr. 1.4301 (AISI 304)	St. Steel W. Nr. 1.4571 (AISI 316 Ti)

DEVICE CLASSIFICATION (acc. to EN 60079-14 and EN 50281-1-2)

CLM-36N	Performance for non-explosive areas
CLM-36NT	High temperature performance, for max. temperatures in coupling place 200°C
CLM-36Xi (only current output)	Performance for explosive areas (combustible dusts, gases or vapours) ☞ II 1 GD T 83°C Ex ia IIB T5 with isolating repeater (e.g. IRU-420). Whole CLM in zone 0 and zone 20
CLM-36XiIT (only current output)	High temperature performance (max. 200°C) for explosive areas ☞ II 1/2 GD T 83°C Ex ia IIB T5 isolating repeater (e.g. IRU-420). Electrode part zone 0 and zone 20, housing zone 1 and zone 21

TEMPERATURE DURABILITY

Variants / Performance	temperature t_m	temperature t_p	temperature t_a
CLM-36N-10, 20	-40°C ... +300°C	-40°C ... +85°C	-40°C ... +85°C
CLM-36N-11, 12, 22	-40°C ... +200°C	-40°C ... +85°C	-40°C ... +85°C
CLM-36N-30	-40°C ... +200°C	-40°C ... +85°C	-40°C ... +85°C
CLM-36N-31 (incl. PR-31)	-40°C ... +130°C	-40°C ... +85°C	-40°C ... +85°C
CLM-36N-31 (incl. KV-31)	-40°C ... +250°C	-40°C ... +85°C	-40°C ... +85°C
CLM-36N-32	-40°C ... +130°C	-40°C ... +85°C	-40°C ... +85°C
CLM-36N-40	-40°C ... +100°C	-40°C ... +85°C	-40°C ... +85°C
CLM-36Xi-10, 20	-40°C ... +200°C	-40°C ... +75°C	-40°C ... +75°C
CLM-36Xi-11, 12, 22	-40°C ... +120°C	-40°C ... +75°C	-40°C ... +75°C
CLM-36Xi-30	-40°C ... +105°C	-40°C ... +75°C	-40°C ... +75°C
CLM-36Xi-31 (incl. PR-31)	-40°C ... +105°C	-40°C ... +75°C	-40°C ... +75°C
CLM-36Xi-31 (incl. KV-31)	-40°C ... +105°C	-40°C ... +75°C	-40°C ... +75°C
CLM-36Xi-32	-40°C ... +105°C	-40°C ... +75°C	-40°C ... +75°C
CLM-36NT-10, 20	-40°C ... +300°C	-40°C ... +200°C	-40°C ... +85°C
CLM-36NT-11, 12, 22	-40°C ... +200°C	-40°C ... +200°C	-40°C ... +85°C
CLM-36NT-30	-40°C ... +250°C	-40°C ... +130°C	-40°C ... +85°C
CLM-36NT-31 (incl. PR-31)	-40°C ... +130°C	-40°C ... +130°C	-40°C ... +85°C
CLM-36NT-31 (incl. KV-31)	-40°C ... +250°C	-40°C ... +130°C	-40°C ... +85°C
CLM-36NT-32	-40°C ... +130°C	-40°C ... +130°C	-40°C ... +85°C
CLM-36XiT-10, 20	-40°C ... +200°C	-40°C ... +200°C	-40°C ... +75°C
CLM-36XiT-11, 12, 22	-40°C ... +120°C	-40°C ... +200°C	-40°C ... +75°C
CLM-36XiT-30	-40°C ... +250°C	-40°C ... +130°C	-40°C ... +75°C
CLM-36XiT-31 (incl. PR-31)	-40°C ... +130°C	-40°C ... +130°C	-40°C ... +75°C
CLM-36XiT-31 (incl. KV-31)	-40°C ... +250°C	-40°C ... +130°C	-40°C ... +75°C
CLM-36XiT-32	-40°C ... +130°C	-40°C ... +130°C	-40°C ... +75°C

Note: For correct function of the level meter must not be exceeded any of the temperature range (t_p , t_m or t_a)

1) The temperatures are clearly explained on Fig. 16.

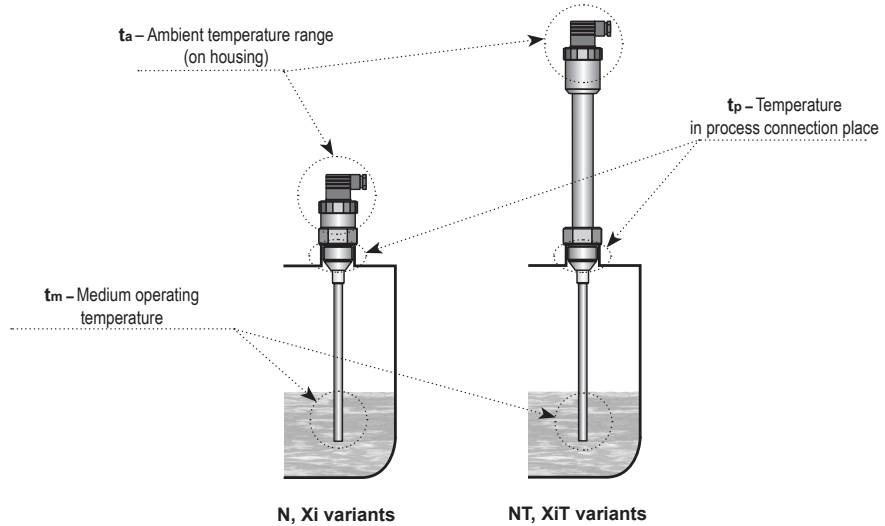

Fig. 16: Points for temperature determination on the level meter

PRESSURE DURABILITY					
Variants / Performance	Maximal operation pressure for temperature t_p				
	to 30°C	to 85°C	to 130°C	to 160°C	to 200°C
CLM-36N-10, 20	7 MPa	5 MPa	–	–	–
CLM-36N-11, 12, 22	4 MPa	2 MPa	–	–	–
CLM-36N-30	7 MPa	5 MPa	–	–	–
CLM-36N-31	–	–	–	–	–
CLM-36N-32	1 MPa	0,5 MPa	–	–	–
CLM-36N-40	0,1 MPa	0,1 MPa	–	–	–
CLM-36Xi-10, 20	7 MPa	5 MPa	–	–	–
CLM-36Xi-11, 12, 22	4 MPa	2 MPa	–	–	–
CLM-36Xi-30	7 MPa	5 MPa	–	–	–
CLM-36Xi-31	–	–	–	–	–
CLM-36Xi-32	1 MPa	0,5 MPa	–	–	–
CLM-36NT-10, 20	7 MPa	5 MPa	3 MPa	2 MPa	1 MPa
CLM-36NT-11, 12, 22	6 MPa	4 MPa	2 MPa	1,5 MPa	0,3 MPa
CLM-36NT-30	7 MPa	5 MPa	3 MPa	–	–
CLM-36NT-31	–	–	–	–	–
CLM-36NT-32	1 MPa	0,5 MPa	0,1 MPa	–	–
CLM-36XiIT-10, 20	7 MPa	5 MPa	3 MPa	2 MPa	1 MPa
CLM-36XiIT-11, 12, 22	6 MPa	4 MPa	2 MPa	1,5 MPa	0,3 MPa
CLM-36XiIT-30	7 MPa	5 MPa	3 MPa	–	–
CLM-36XiIT-31	–	–	–	–	–
CLM-36XiIT-32	1 MPa	0,5 MPa	0,1 MPa	–	–

18. TABLE OF RELATIVE PERMITTIVITY

MATERIAL	ϵ_r
Acetone	19,5 ÷ 21,4
Acetylentetrachloride	8,1
Aminoplasts	5 ÷ 8
Ammonia	15 ÷ 24
Aniline	6,9
Ash	1,5 ÷ 1,7
Benzaldehyde	18,3
Benzene	2,28 ÷ 2,3
Benzol	2,3
Celluloide	3,5 ÷ 6,2
Cement	4,0
Dioxane	2,235
Ebonit	2,5 ÷ 5
Ethanol	24
Ethylacetate	6,0
Ethyleneglycol	38,7
Ethylenechloride	10,5
Flint crystal	4,5
Flour	2,5 ÷ 3,0
Food salt (NaCl)	6,0
Freon R22	6,1
Fused quartz	3,7
Gasoline (benzin)	2,0 ÷ 2,2
Glass	3,7 ÷ 10
Glass organic	3 ÷ 3,6
Glass silicate	16
Glazed carton	3,5
Glycerine	47
Grains	3,0 ÷ 5,0
Hardened textile	2 ÷ 6
Hexane	1,9

MATERIAL	ϵ_r
Chloroforme	4,81
Ice	3,1
Liquefied air	1,5
Liquefied CO2	1,6
Liquefied chlore	2,0
Liquefied propan	1,6 ÷ 1,9
Marble	9,3 ÷ 11,6
Methanol	32,7 ÷ 33,8
Mica	5 ÷ 8
Mikanite	4,5 ÷ 6
Milk powder	3,5 ÷ 4
Monochlorbenzene	4,0
Nitrobenzene	35,7
Ortonitrotoluene	27,4
Paper	1,6 ÷ 2,6
Paraffin	1,9 ÷ 2,5
Paraffin oil	1,9 ÷ 2,5
Paraffinic oil	2,2
Petroleum	2,0 ÷ 2,2
Polyacetal	3,6 ÷ 3,7
Polyamide - PA	4,0 ÷ 5,0
Polydichlorstyrole	2,7
Polyetheretherketone - PEEK	3,2
Polyetherimide - PEI	3,0
Polyethylene - PE	2,16
Polyfenylenesulfide - PPS	3,3
Polymethylmetakrylate	2,56
Polypropylene - PP	2,0 ÷ 2,2
Polystyrole	2,39
Polysulphone - PSU	3,0
Polytetrafluorethylene - PTFE	2,0 ÷ 2,1

ϵ_r ... dielectric constant

MATERIAL	ϵ_r
Polyvinylacetate	2,7
Polyvinylchloride - PVC	2,51 ÷ 3,1
Polyvinylidene fluoride	6,0 ÷ 7,4
Porcelain	4,5 ÷ 7
Pyridine	13,6
Rape-seed (colza) oil	2,8
Resin - acrylic	2,4 ÷ 4,5
Resin - epoxy	2,5 ÷ 8,0
Resin - melamine	4,7 ÷ 10,2
Resin - phenolic	4,0 ÷ 12,0
Resin - polyester	2,8 ÷ 8,1
Resin - styrene	2,3 ÷ 3,4
Resin - ureal	5,0 ÷ 8,0
Rubber	2,0 ÷ 6,0
Sand	3,0 ÷ 5,0
Silicon caoutchouc	2,8 ÷ 3,3
Succinite	2,9
Sugar	3,0
Sulphur	3,4 ÷ 3,6
Toluene	2,3 ÷ 2,38
Trichlorethylene	3,43
Trolitule	2 ÷ 2,6
Vaseline	2,2 ÷ 2,9
Water	81
Water solution	50 ÷ 80
White beeswax	2,0 ÷ 2,9
Wood - damp	10 ÷ 30
Wood - dry	2 ÷ 6

19. PACKAGING, SHIPPING AND STORAGE

The device CLM-36 is packaged in a polyethylene bag, and the entire consignment is placed into a cardboard box. A suitable filler material is used in the cardboard box to prevent mechanical damage during transport.

Remove the device from the packaging only just before using, thereby protecting it from potential damage.

A forwarding company will be used to ship goods to the customer. Upon prior agreement, ordered goods can be picked up in person at company headquarters. When receiving, please check to see that the consignment is complete and matches the order, or to see if any damage has occurred to the packaging and device during transport. Do not use a device clearly damaged during transport, but rather contact the manufacturer in order to resolve the situation.

If the device is to be further shipped, it must be wrapped in its original packaging and protected against impact and weather conditions.

Store the device in its original packaging in dry areas covered from weather conditions, with humidity of up to 85 % without effects of chemically active substances. The storage temperature range is -10°C to +50°C.



All level meters except type variants CLM-36_30, 31, 32 are given protective covers at ends of electrodes (longer than 100 mm) and of reference tubes in order to prevent damage to electrode and tubes, tearing of the package or injury of persons handling them. Remove the cover prior to putting into operation.

Dinel[®]

industrial electronics

Dinel, s.r.o.

U Tescomy 249
760 01 Zlín
Czech Republic

Tel.: +420 577 002 003
Fax: +420 577 002 007
E-mail: sale@dinel.cz

www.dinel.cz

The latest version of this instruction manual can be found at www.dinel.cz

Version: 11/2015



QMS
ISO 9001

