

- For continuous level measurement of clean, lightly soiled, or sludge water in non-pressure reservoirs, boreholes, tanks etc.
- Precise customer choice of the measurement range up to 100 m (H₂O)
- The health certificate for contact with potable water available
- Current or Voltage output
- Easy "plug and play" installation without any settings



Hydrostatic level meter HLM-25C is compact measuring device containing ceramic tensometric sensor and evaluation electronics in stainless steel probe. Ceramic sensor is resistant to lightly soiled, or sludge water. From the probe housing comes out 2-wire cable with capillary (for atmospheric pressure compensation). The front side of the sensor is open, therefore the level meter is resistant to capture gross (solid) impurities. The level meter has no customer-accessible adjusting elements.

VARIANTS OF SENSORS

- **HLM-25C** **Measuring range 1 ... 100 m H₂O**, arbitrary measurement ranges (customer configurable in 10 cm step). Current (4 ... 20 mA) or voltage (0 ... 10 V) output, performance for non-explosive areas.

DIMENSIONAL DRAWING

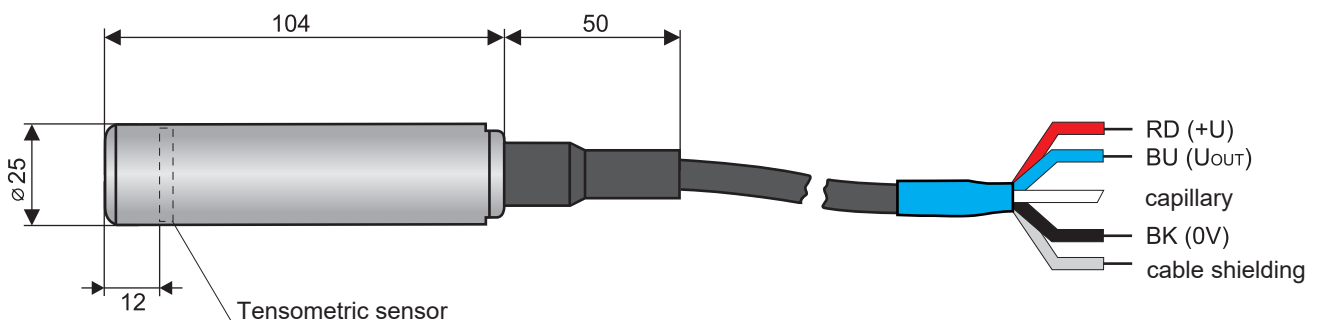

TECHNICAL SPECIFICATIONS

TECHNICAL SPECIFICATION		
Supply voltage	HLM-25C-____-I HLM-25C-____-U	12 ... 34 V DC 12 ... 34 V DC
Current output	HLM-25C-____-I	4 ... 20 mA
Voltage output	HLM-25C-____-U	0 ... 10 V
Power consumption (off-load)	HLM-25C-____-U	Max. 8 mA
Pressure permissible overload		1,5x range
Basic error – accuracy (hysteresis, repeatability, non-linearity)		0,4% of range
Long-term stability		0,3% / Year
Temperature error (for 0 ... +50°C)		Max. 0,04% / K
Compensated temperature range		0 ... +50°C
Ambient temperature range (medium temperature)		-20 ... +70°C
Maximal load resistance for current output (U = 24 V DC)		$R_{max} = 600 \Omega$
Minimal load resistance for voltage output		$R_{min} = 1 \text{ k}\Omega$
Protection class		IP68
Used materials	Probe housing Membrane Sealing O-rings Cable isolation Cable gland	St. steel W.Nr. 1.4404 (AISI 316L) Ceramic Al ₂ O ₃ 96% FPM; EPDM Plastic PE Silicon ELASTOSIL
Weight	Sensor Cable (1 m)	180g 60g

RANGE OF APPLICATION

For continuous measurement of water level even slightly contaminated without coarse impurities in pressureless tanks, boreholes, wells, sumps, reservoirs and swimming pools. The measured water should be chemically neutral (pH 7.2 - 7.6) and should not contain increased amounts of chlorine. If the water is not chemically neutral, foreign bodies made of other metallic materials (especially copper or brass) must not be placed in the measured space. Failure to follow these guidelines may result in corrosive damage to the stainless steel sensor housing. The suitability of using the level meter for measuring liquids other than water must be consulted with the manufacturer.

INSTALLATION INSTRUCTIONS

- Installation is done by hanging the probe down into the measured area (tanks, boreholes). The probe is left hanging on the cable, or is placed on the bottom. If the probe is **hung deeper than 50 m**, it is necessary to use a **cable hanger KD-60** (see picture). During installation of the probe, it is need to be carefull to avoid damaging the ceramic membrane. Do not throw the probe into the tank or the borehole, but with caution, run it smoothly to the bottom. If the probe is submerged fast into the liquid, the ceramic membrane can be pressure overload and thus irreversible damaged.
- Kabel obsahuje vyrovnávací **kapiláru**, proto je nutné k jeho napojení na návaznou kabeláž použít **nehermetické** přípojně krabice.
- Při stáčení přebytečného kabelu do svazku musí být zachován průměr kruhu min. 30 cm. Kabel **nedoporučujeme** zkracovat či jinak mechanicky upravovat.
- In tanks where there are **strong turbulences or waves**, the probe should be placed in the stilling tube, behind the wall, or at least at the maximum possible distance from the source of turbulence. If the tank vibrates or contains a swirling medium, it is need to protect the probe against collisions with walls or the bottom of the tank.
- When using **other liquid than water** it is needed to make the output correction with respect to the density of the liquid, eventually **consult the application** with the manufacturer.



Cable hanger KD-60

ELECTRICAL CONNECTION

The sensor is connected to the evaluation (control, display) units through the connecting cables. Connection scheme is shown on pictures. Electrical connections must be always done in voltage-free state! The power supply unit must be a source of safe voltage which can be a part of the evaluation or display device.

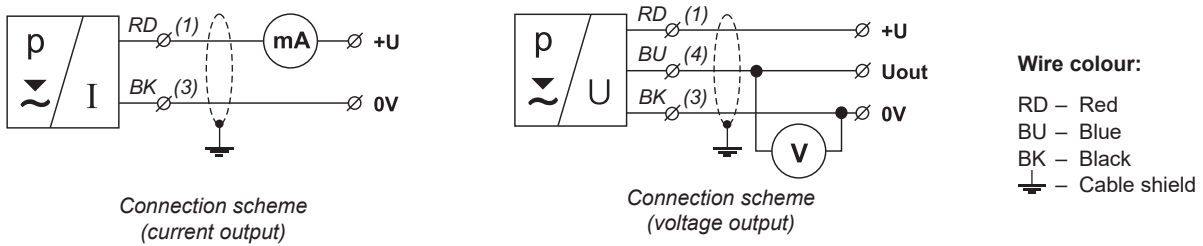

Electrical connection can only be made in a voltage-free state!

In the event that the level meter is fitted with a shielded cable, it is necessary to ground the cable on the side of the power source for the event of a possible lightning electrical discharge in the vicinity of the sensor.

In the event that the level meter is installed in an outdoor environment at a distance greater than 20 m from the outdoor switchboard, or from an enclosed building, it is necessary to supplement the electrical cable leading to the level meter with suitable overvoltage protection.

In case of strong ambient electromagnetic interference, paralleling of conductors with power distribution, or for distribution to distances over 30m, we recommend using a shielded cable and its grounding on the side of the power source.

CONNECTION EXAMPLES

CONNECTION OF LEVEL METER HLM-25-C-I WITH CURRENT OUTPUT TO THE UNIT PDU-4xx-P (OUTPUT 4 ... 20 mA) USING JUNCTION BOX NB

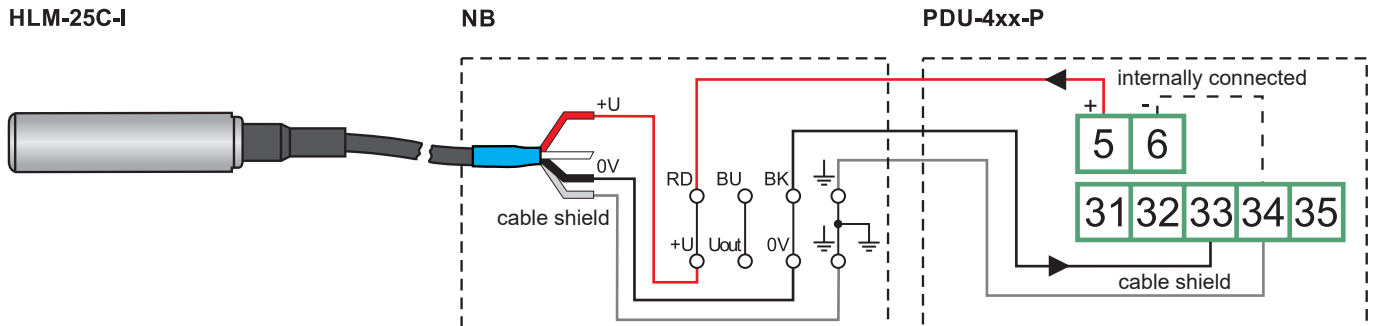

In the case using a connection box with integrated overvoltage protection, the sensor needs to be connected to the bottom series of terminals. This series of contacts is marked by label SENSOR.

CONNECTION OF LEVEL METER HLM-25-C-U WITH VOLTAGE OUTPUT TO THE UNIT PDU-4xx-P (OUTPUT 0 ... 10 V) USING JUNCTION BOX NB

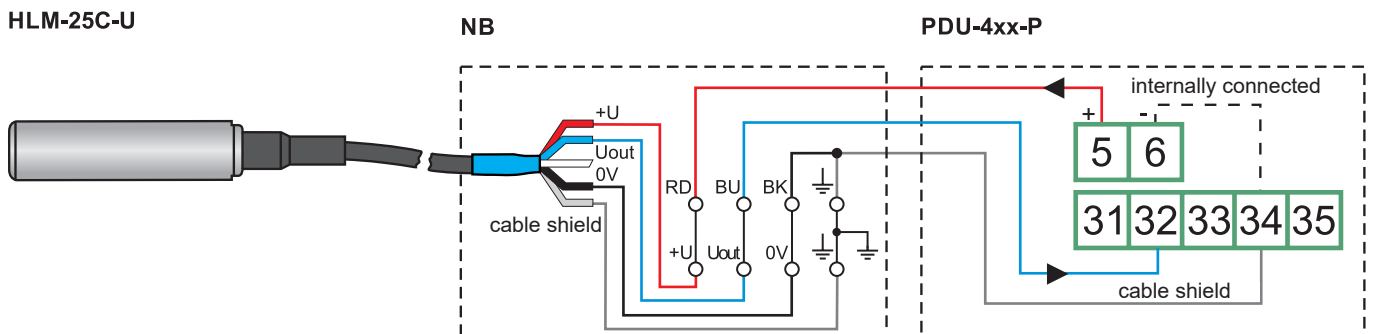

In the case using a connection box with integrated overvoltage protection, the sensor needs to be connected to the bottom series of terminals. This series of contacts is marked by label SENSOR.

CONNECTION OF LEVEL METER HLM-25-C-I WITH CURRENT OUTPUT TO THE UNIT PDU-4xx-W (OUTPUT 4 ... 20 mA) USING JUNCTION BOX NB

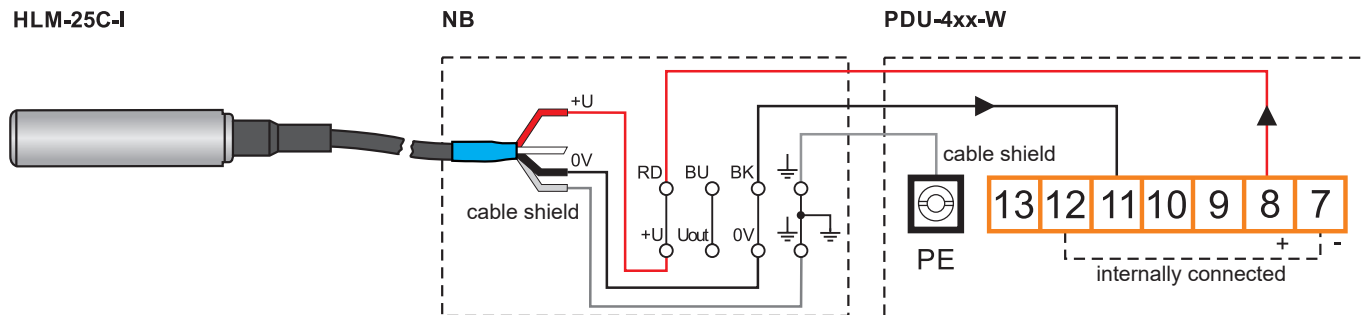

In the case using a connection box with integrated overvoltage protection, the sensor needs to be connected to the bottom series of terminals. This series of contacts is marked by label SENSOR.

CONNECTION OF LEVEL METER HLM-25-C-U WITH VOLTAGE OUTPUT TO THE UNIT PDU-4xx-W (OUTPUT 0 ... 10 V) USING JUNCTION BOX NB

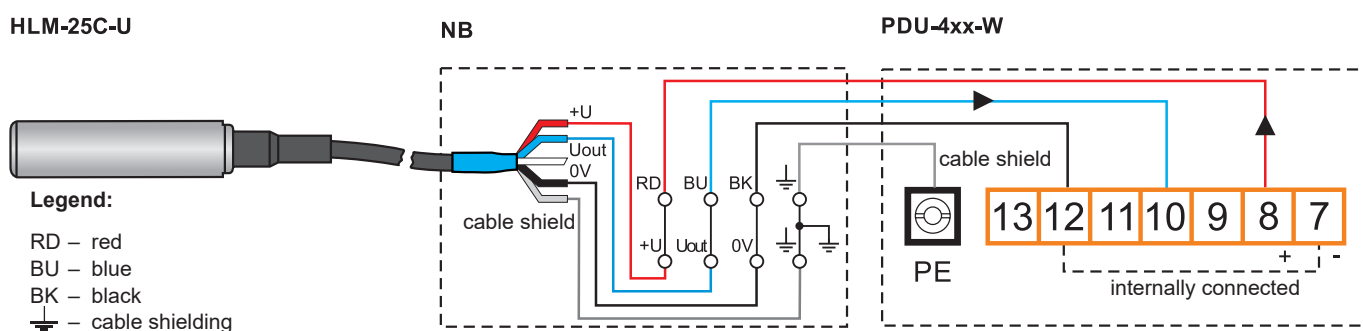

In the case using a connection box with integrated overvoltage protection, the sensor needs to be connected to the bottom series of terminals. This series of contacts is marked by label SENSOR.

ORDER CODE

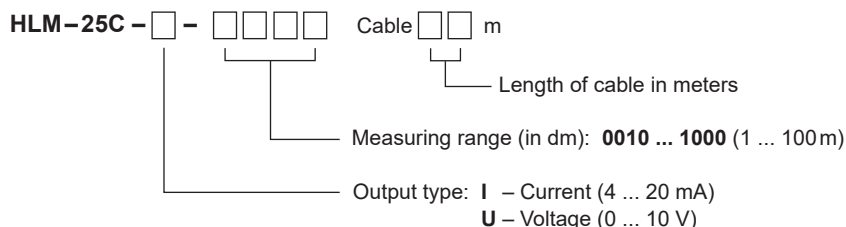

CORRECT SPECIFICATION EXAMPLES

HLM-25C-I-0010 cable 3 m

(I) Current output 4...20 mA. **Measuring range 1 m**, cable 3 m.

HLM-25C-I-0200 cable 25 m

(I) Current output 4...20 mA. **Measuring range 20 m**.

HLM-25C-U-0500 cable 52 m

(U) Current output 0...10 V. **Measuring range 50 m**, cable 52 m.

ACCESSORIES

optional – for a surcharge (see catalogue sheet of accessories)

- Cable hanger KD-60
- Nehermetic connection box NB

SAFETY, PROTECTION AND COMPATIBILITY

Level meter HLM-25C is equipped with protection against voltage polarity reversal, protection against current overload and protection against short term overvoltage.

Protection against dangerous contact is provided by low safety voltage according to 33 2000-4-41.

Electromagnetic compatibility is provided by conformity with standards EN 55011/B, EN 61326-1, EN 61000-4-2 (8 kV), -4-3 (10 V/m), -4-4 (2 kV), -4-5 (1 kV) and -4-6 (10 V).

PACKAGING, SHIPPING AND STORAGE

The HLM-25C device is supplied packaged in a cardboard box that protects it against mechanical damage.

When handling and during transport, it is necessary to prevent impacts and falls.

The HLM-25C electrical device must be stored in dry enclosed areas with humidity up to 85%, free of aggressive vapours at temperatures between -25°C and 70°C, and must be protected against the effects of weather.

version: 08/2020



QMS
ISO 9001

Dinel, s.r.o.
U Tescomy 249
760 01 Zlín, Czech Republic

Phone: +420 577 002 003

HLM-25C-dat-5.5

sale@dinel.cz
www.dinel.cz