



## ELECTROMAGNETIC FLOWMETER EFM-115

---

Firmware: v1.32



## CONTENT

---

<b>1. Measuring principle</b> .....	4
<b>2. Dimensional drawing</b> .....	4
<b>3. Installation instructions</b> .....	5
<b>4. Electrical connection</b> .....	7
<b>5. Terminals location</b> .....	7
<b>6. Inputs and Outputs connection</b> .....	8
<b>7. Signalization</b> .....	8
<b>8. Instructions for use</b> .....	9
8.1. Keyboard.....	9
8.2. S + Q menu decription - user mode .....	9
8.3. Graphic structure of individual menus.....	10
8.4. Explanation the access password (service mode).....	10
8.5. Instructions for use - detailed menu descriptions.....	11
<b>9. Flowmeter assembly and application</b> .....	21
<b>10. Order code</b> .....	21
<b>11. Examples of correct code</b> .....	21
<b>12. Safety, protection and compatibility</b> .....	21
<b>13. Use, manipulation and maintance</b> .....	22
<b>14. Marking of labels</b> .....	22
<b>15. Specification</b> .....	23

## SAFETY



All operations described in this instruction manual have to be carried out only by trained personnel or an accredited person. Warranty and post warranty service must be exclusively carried out by the manufacturer.

Improper use, installation or set-up of the flowmeter can result in crashes in the application.

The manufacturer is not responsible for improper use, losses of work caused by either direct or indirect damage, and for expenses incurred during installation or use of the flowmeter.

## 1. MEASURING PRINCIPLE

The **Electromagnetic flowmeter EFM-115** is precise measuring device intended for the measurement of liquid flow of electrically conductive media. The meters may be used for measurements, registration, dosing, mixing, etc. The measurement is based on the principle of Lorentz law. In compliance with this law, electric voltage is induced in an electrically conductive body, which moves across a magnetic field.

## 2. DIMENSIONS DRAWINGS

### CONTROL UNIT

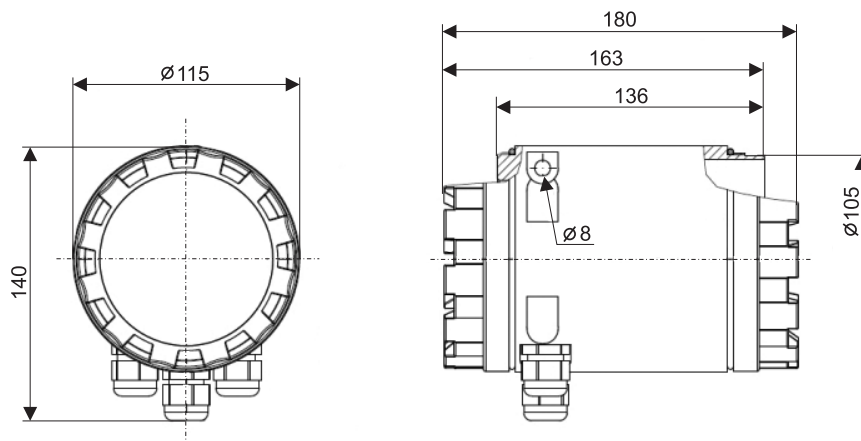

### SENSOR

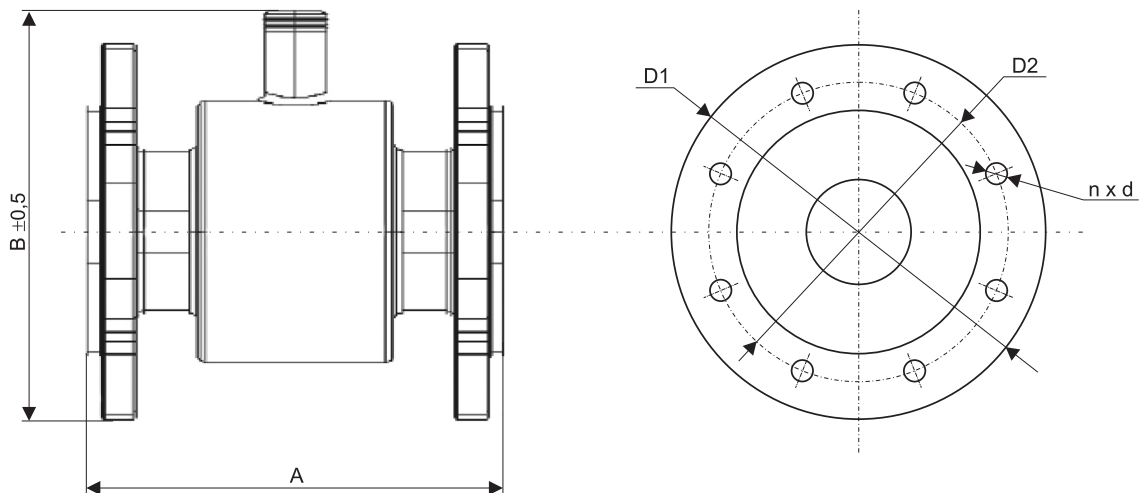

**TABLE FOR 1 m/s FLOWRATES**

DN	m³/h	l/min	l/s
15	0,637	10,62	0,177
20	1,131	18,85	0,314
25	1,767	29,452	0,491
32	2,895	48,255	0,804
40	4,524	75,398	1,257
50	7,069	117,81	1,964
65	11,946	199,10	3,318
80	18,096	301,59	5,027
100	28,274	471,23	7,854
125	44,179	736,31	12,272
150	63,617	1060,3	17,671
200	113,10	1885,0	31,420

**CONSTRUCTIONAL DIMENSIONS AND WEIGHTS OF FLOWMETERS**

DN	PN	Dimensions [mm]						Weights [kg]
		A	B	D1	D2	d	n	
15	16	150	155	95	65	14	4	2,5
20	16	150	160	105	75	14	4	3,0
25	16	150	167	115	85	14	4	3,5
32	16	150	180	140	100	18	4	5,0
40	16	150	185	150	110	18	4	6,0
50	16	200	191	165	125	18	4	7,0
65	16	200	209	185	145	18	4	8,0
80	16	200	224	200	160	18	8	9,5
100	16	250	245	220	180	18	8	12
125	16	250	276	250	210	18	8	15
150	16	300	305	285	240	22	8	20
200	16	350	375	340	295	22	12	36

### 3. INSTALLATION INSTRUCTIONS

#### Sensor location and its position in piping

- The inductive flowmeter sensor can be installed in any position according to requirements, however for horizontal assembly, the electrodes axis always be horizontal (ie. base for the control unit must be positioned vertically upside )
- Sensor must remain full of liquid.
- It is recommended that the flow direction should follow the arrow on the sensor cover, the converter is also preset for this direction. On the operating meter, it is possible to adjust the reverse flow direction by changing the Checkmag converter parameter.
- Bolts and nuts - verify if there is a sufficient space for their installation near flanges.
- Vibration and deflection of piping - fix the piping on both sides from the flowmeters to avoid any deflection and vibrations.
- If you install any pipes with higher internal diameters, install a reducer, this will provide an axial shift without increased mechanical stress of piping and sensor flanges.
- To improve flow, use only the recommended straight lengths upstream (5DN) and downstream of the sensor (3DN). Any change of a diameter with an angle up to 8° is excluded from the above-mentioned straight lengths. Suitably assembled flow deflectors and a combination of diffusers are used in more sophisticated installations.
- When you install the sensor in insulated piping (e.g. glass, artificial mass, etc.), use proper sealing ground rings. A conductive connection between a sensor ground point and the liquid to be measured is needed for a proper measurement!

#### Recommended position for sensor installation

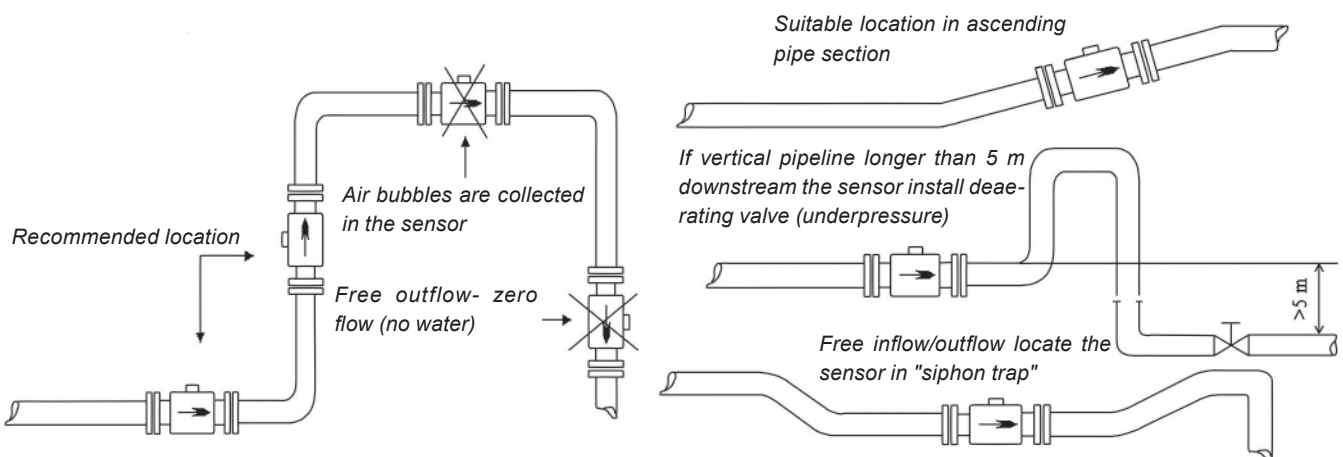

#### Recommendations for installation

To avoid any measurement errors which are caused by air bubbles or failures on the lining, pay attention to the following recommendations:

- During assembling correctly seat the sensor, tighten screws uniformly and move on a diagonal one after another.
- It should be noted that the parallelism of flanges has a greater effect on packing than excessive tightening forces on curved and seated flanges.
- The sensor must be installed inside piping so that the axis of sensor electrode is always **horizontal**.

- Packing - The extended part of lining does not operate properly as a seal, hence appropriate packing must be inserted between sensor and pipeline. If the packing protrudes into a flow profile at any point, this will cause turbulence and reduce the measurement quality.
- During installation, make sure the sensor slides into piping if the pipeline is not flexible enough. It is recommended that installation insert (especially for greater internal diameters) should be used. During installation of the sensor, counterflanges must not be welded (danger of the sensor lining failure).

### Checkmag grounding

- For reliable and proper operation of the inductive meter, it is necessary to use high-quality protective grounding. Internal flowmeter cables and power supply PE (PEN) conductors provide protective grounding. Working grounding is also provided via internal cables and a high-quality connection of the sensor body with two metal pipe counterflanges. It is recommended that a connection made with M6 welded screws or bored threaded holes is used. The connection under flange fixing screws is not recommended because of possible corrosion resulting in measurement failures.
- When assembled into piping made from non-conductive material (or with non-conductive lining), it is necessary to provide working grounding with liquid by a different method, e.g. by grounding rings- valid for DN 15 - DN 40. The rings can be ordered from factory, their material and chemical resistant must comply with the liquid to be measured - usually produced from the same material as sensor electrodes. The flowmeters from DN 50 - DN 200 are equipped of grounding electrode. Function of grounding electrode is same as grounding ring.
- When assembled, it is necessary to insert the packing on both sides of the grounding ring. Make sure that no parts will protrude into a internal sensor profile (turbulence).

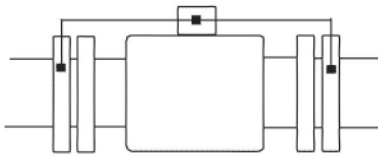

*Drawing of sensor working grounding inside pipeline*

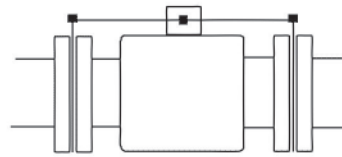

*Use of grounding rings for DN 15 až DN 40*

### Checkmag commissioning

- Checking installation and connections
- Proper sensor and grounding
- Tightening all cable connection clamps and plug in all connection.
- Verify the completeness of the shipped set according to the serial numbers of sensor and converter.
- Verify proper supply voltage, see the label on the converter.
- Verify proper electrical protection.
- If the installation is fault-free, fill the pipeline with liquid and verify the sensor tightness inside the pipeline. After short washout, switch the system on-off-on.

### Measurement conditions

The following conditions must be achieved for reliable Checkmag operation and measurement precision

- Minimum liquid conductivity >20  $\mu\text{s}/\text{cm}$  for demineralised cold water  
>5  $\mu\text{s}/\text{cm}$  for other fluids
- Flowrate min. 0,3 m/s, max. 12 m/s
- Steady flowrate straight lengths 5 DN upstream / 3 DN downstream,  
for any DN changes a bevel up to 8° is included in straight lengths
- Sensor completely filled with liquid.
- High-quality connection between sensor and liquid.

Measurement precision is negatively affected by:

- Liquid aeration, air bubbles
- Strong stray earth currents
- Non lamina flow
- Solid or magnetic metals in the medium to be measured

## 4. ELECTRICAL CONNECTION

Converter connection to power supply must be performed in compliance with the standards and rules to be effective:

- **Connection of electrical instruments and appliances**
  - **Protection against electric shock**
  - **Heavy current distribution network in industrial plants**
  - **Safety operational rules for electrical installations operated by low-level experienced personnel.**
- 
- If requested our Service Division will carry out commissioning. If work is done by any different organisation, the warranty can be cancelled in the case of such unauthorised work.
  - Signal and output cable routing should not be located near power output distribution network or in common ducts.



Signal cable connection:

- Signals which are transmitted from a sensor electrode circuit to the converter will be in a range of millivolts. They will be very sensitive to magnetic and electrostatic interference from neighbouring high-voltage cables, power supply cables and high power output motors, etc. The interference is mainly compensated for by the converter connection, nevertheless if possible, it is necessary to prevent all spurious signals.
- The signal cable is of a special construction and length and is a part of the shipment, its length should not be changed (for certificated meter must not be changed). The proper cable connection to the converter is important, doing so may cause measurement failures. Special requirements are laid on shielding, and the measurement precision depends on its quality.
- The cable must not be extended.
- The shielding must be well insulated on the whole route from ground and the metal subjects. It is recommended that the cable is located in a separate conduit or trays.

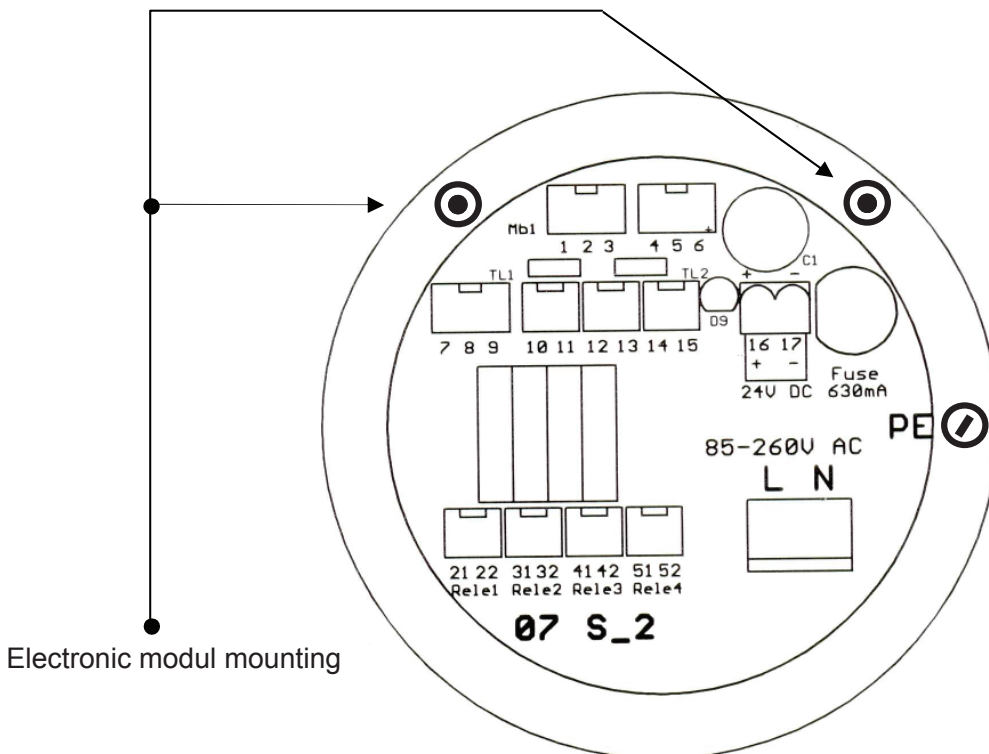
## 5. TERMINALS LOCATION



## 6. INPUTS AND OUTPUTS CONNECTION

	TERMINALS	PERFORMANCE	
		standard	optional
SENSOR	1	Yellow	Driving
	2	Green	Driving
	3	Braiding	GND and Shielding
	4	E2 Brown	Signal
	5	Braiding	Shielding
	6	E1 White	Signal
COMMUNICATION	7		RS-485 / Modbus RTU A B Not connected (Cable max. 500m)
	8		
	9		
OUTPUTS	10		Analog output (active)
	11		
	12	Not connected	
	13	Not connected	
	14		Frequency output 0 ... 1 kHz (passive)
15			
SUPPLY POWER	16	85 ... 260 V AC	9 ... 36 V DC
	17	Not connected	Not connected
	L	Not connected	Not connected
	N	L	+ 9 ... 36 V
	PE	N PE	0 V PE conductor
RELAYS	21 22		Relay 1 – 250 V AC; < 30 V DC / < 3 A  Relay 2 – 250 V AC; < 30 V DC / < 3 A  Relay 3 – 250 V AC; < 30 V DC / < 3 A  Relay 4 – 250 V AC; < 30 V DC / < 3 A
	31 32		
	41 42		
	51 52		

## 7. SIGNALIZATION

LED	Color	Function
„A“	Red	signalization of pulse signal, which is applied to coils of the sensor
„B“	Green	voltage signal which is induced between the two measuring electrodes

## 8. INSTRUCTIONS FOR USE

### 8.1. KEYBOARD

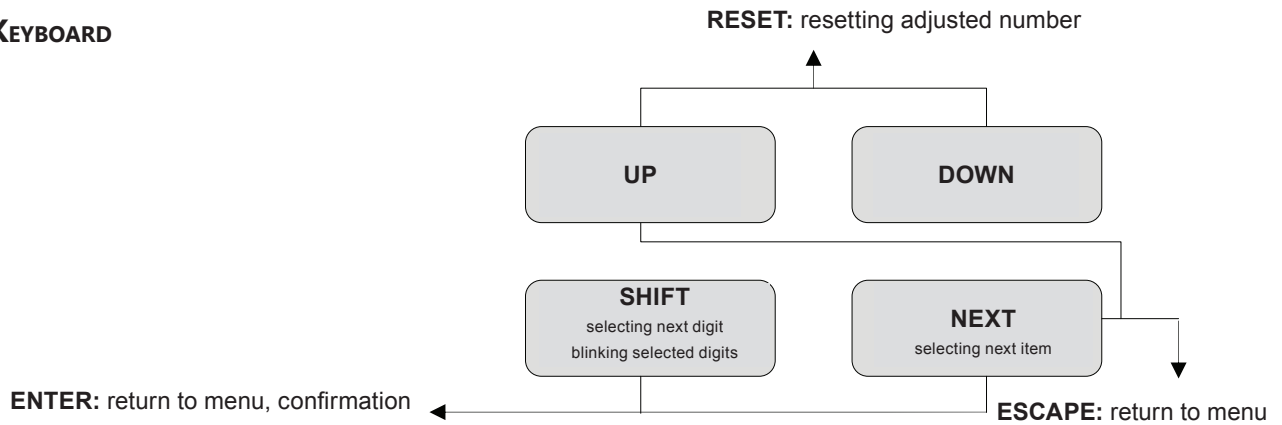

### 8.2. S + Q MENU DESCRIPTION- USER MODE

**S + Q -** Displaying current flow in both directions, total volume in both directions, closing a relay. Individual items can be selected in **MAIN** main, **Display** box.

#### RUN menu description - measurement mode, reading the statistic data:

- Standard view -** Moving from user menu and return.
- Q(t) record -** Recording 5 average flowrates.
- H-statistics -** Hourly statistics: total volume, operational time and flowmeter failure time.
- D-statistics -** Daily statistics: total volume, operational time and flowmeter failure time.
- M-statistics -** Monthly statistics: total volume, operational time and flowmeter failure time.
- Date/time view -** Displaying the date and time.
- Password check -** Selecting four - digit password which is necessary for moving from RUN to MAIN menu.
- Version -** Instruments type and program version.

#### MAIN menu description- instrument adjustment:

- Run -** Moving to measurement mode, reading the statistical data and return.
- Run / s -** Running in service mode (intended for installing and testing the instrument).
- Qsupp,.. -** low flow rejection limit, identifying positive flow direction, *measurement delay after switching on.*
- Filter -** *filtration constant and filter delay.*
- Range -** *current flow range.*
- Display -** time parameters that display the individual quantities, displaying individual quantities.
- Unit, format -** flowrate unit Q and format of displaying the quantities Q, S+ and S-
- Pulse output -** pulse output for the the external counter, total volume per one pulse, pulse width.
- Comparators -** four flow comparators with 4 modes, static or pulse mode.
- Failure -** intended for future checking status parameters.
- Relays -** assigning the functions for relays 1 to 4, external counter pulse output, 1 to 4 comparator outputs, failure, aerating the sensor.
- Analog output -** assigning output quantity, output range, nominal current (0-20, 4-20, 0-5, 0-10 mA), extending current range above the upper limit on nominal current (e.g. up to 24 mA), negative output range.
- RS 485 -** *entering transmission line parameters*
- Manual output -** manual control (testing) of 1 to 4 relays, current and frequency outputs.
- Zero adjust -** adjusting device zero point: performance during calibration in factory, after installation can be completed.
- Recalibration -** *adjusting parameters of automatic internal recalibration in the measurement mode.*
- Air detector -** *adjusting detection parameters of empty piping.*
- Cleaner -** *adjusting parameters for cleaning sensor electrode.*
- Date, time -** adjusting the date and time: for initialisation press only NEXT key and hold for 3 seconds.
- Password -** adjusting the password for moving cross the main menu. More information on page 10.
- Version -** instrument type and program version.

**CAUTION:** The description in the MAIN menu written in Italics should not be changed. The parameters are preset with respect to the given location and the sensor type.

### 8.3. GRAPHIC STRUCTURE OF INDIVIDUAL MENUS

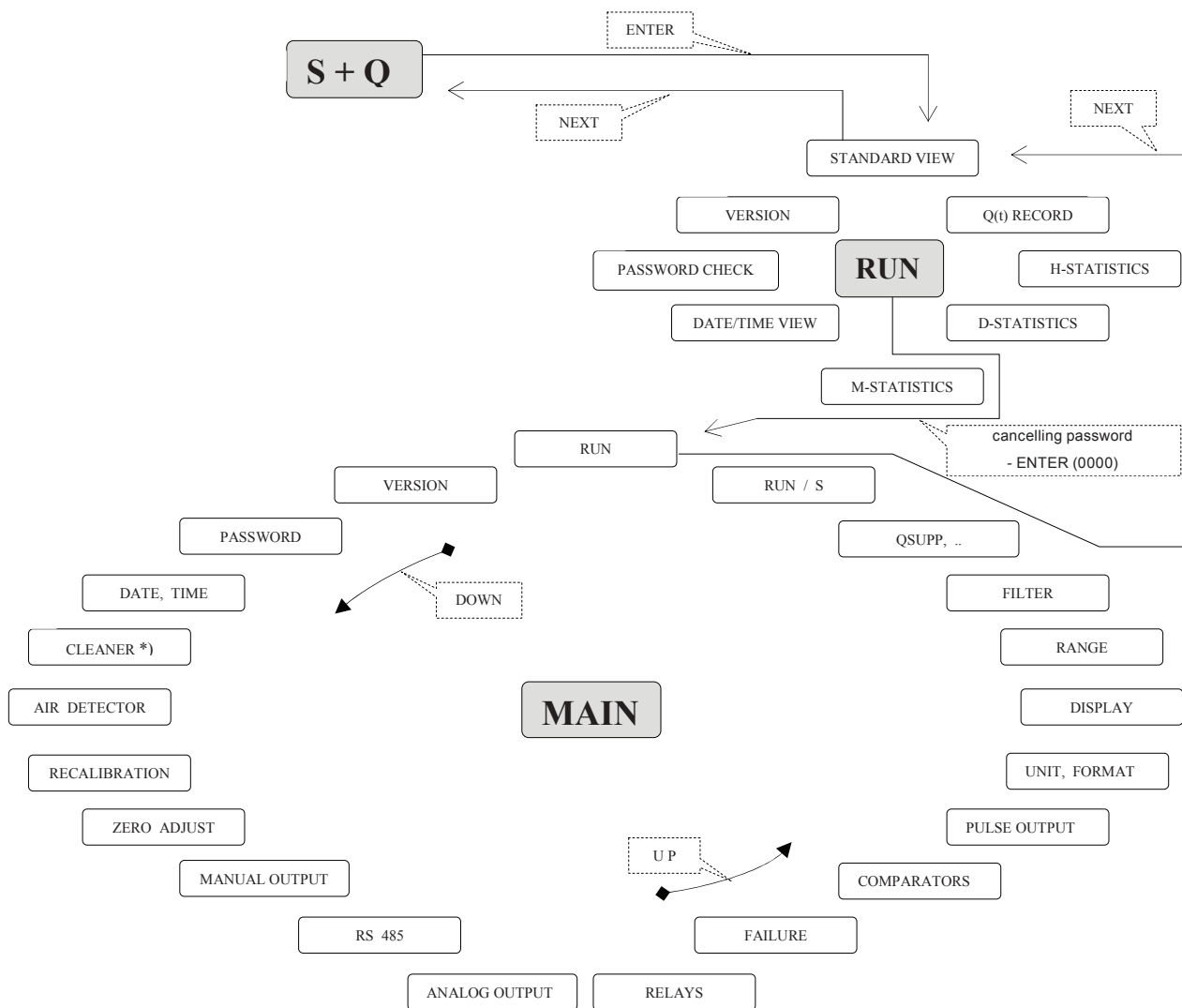

## 8.5. INSTRUCTIONS FOR USE - DETAILED MENU DESCRIPTIONS

### S + Q - user menu:

The program identification and the program version will be displayed during the first three seconds after switching on the instrument. The individual screens of selected quantities will alter (in preset time intervals) automatically after the elapse of a 3-second interval, pressig the NEXT button may also alter the screens. The screens and the intervals may be selected in the **MAIN** menu, and **Display** screen.

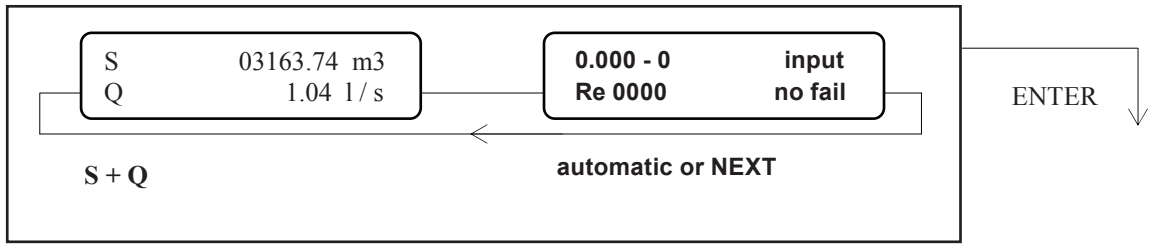

**Standard view** - moving from the user mode and return: The measurement is proceeding.



**Q (t) record** - recording 5-minute average flowrates Q, The measurement is proceeding.

Key functions - UP or DOWN, selection in 5-minute steps, UP+DOWN resets hours and minutes, SHIFT+UP or DOWN - selects the days.

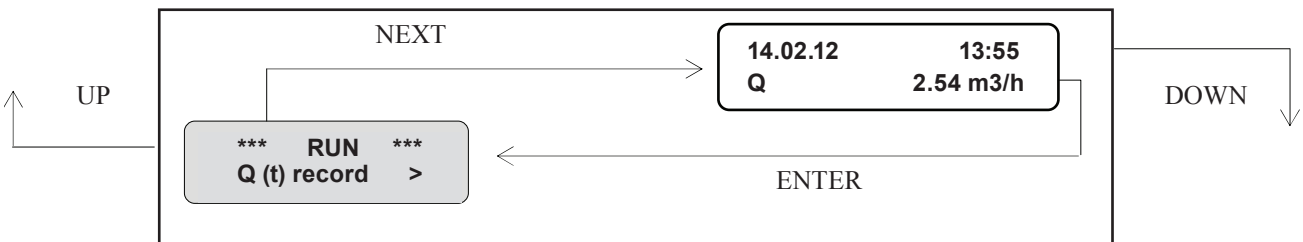

**H-statistics** - hourly statistics, total volume S, measurement time T and failure time Tf for every hour: The measurement is proceeding. Key functions - UP or DOWN, selection in hours, UP+DOWN resets the clock, SHIFT+UP or DOWN - selects the days.

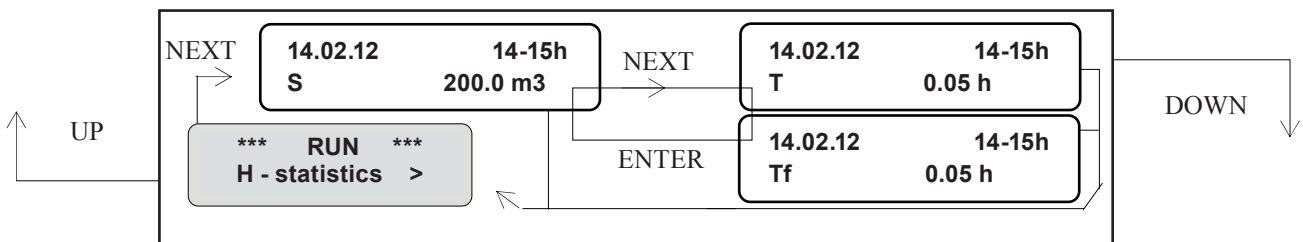

**D-statistics** - daily statistics, total volume S, measurement time T and failure time Tf for every day, The measurement is proceeding. Key functions - UP or DOWN, selection in days, SHIFT+UP or DOWN - selects in months.

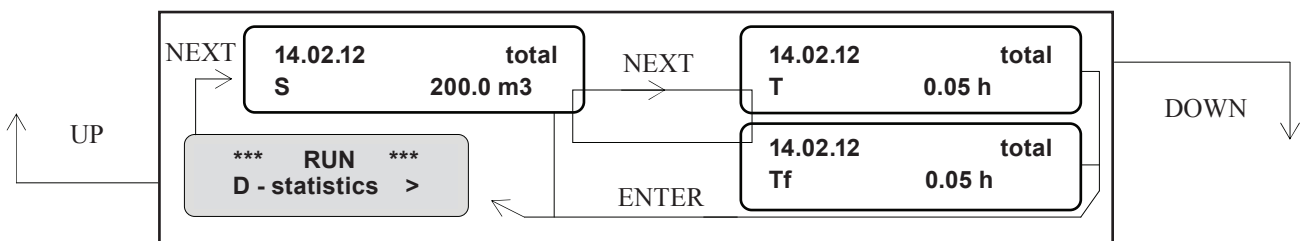

**M-statistics** - monthly statistics, total volume S, measurement time T and failure interval Tf for every month. The measurement is proceeding. Key functions - UP or DOWN selection in months.

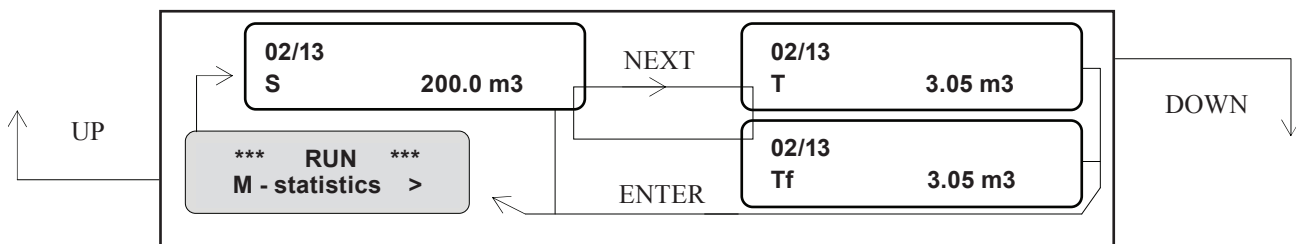

**Date/time view** - the date and time: The measurement is proceeding.

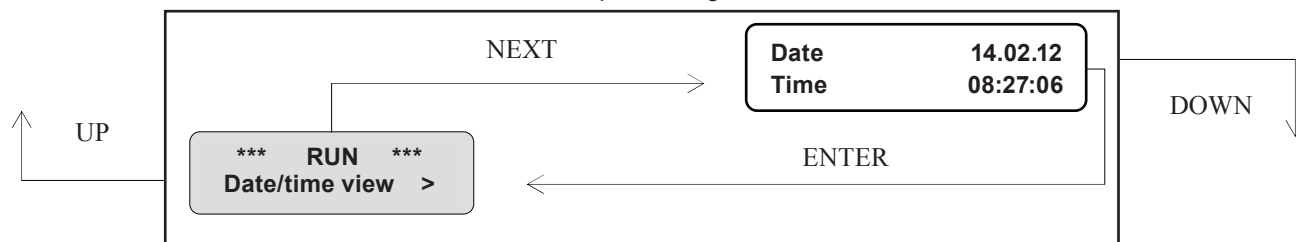

**Password check** - selecting 4-digit password: The measurement is proceeding. The password is necessary for moving from RUN to MAIN. The access code for moving in the device menu is set in the factory and it is located on black label at terminals of control unit.

Key functions - SHIFT selecting the next digit (selected digits are blinking), UP or DOWN selecting the numbers.

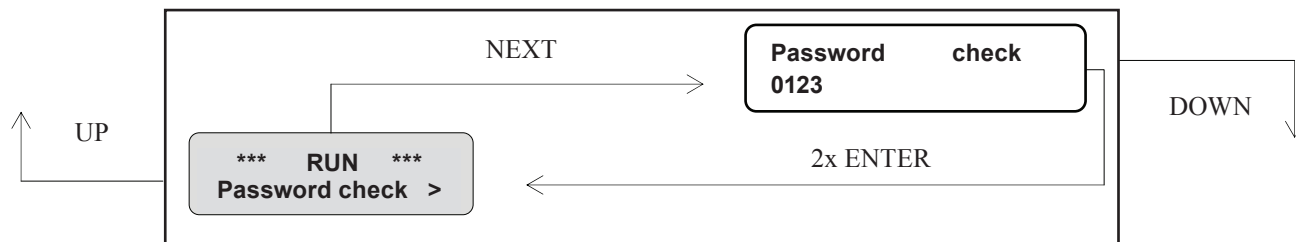

**Version** - the instrument type and program version: The measurement is proceeding.

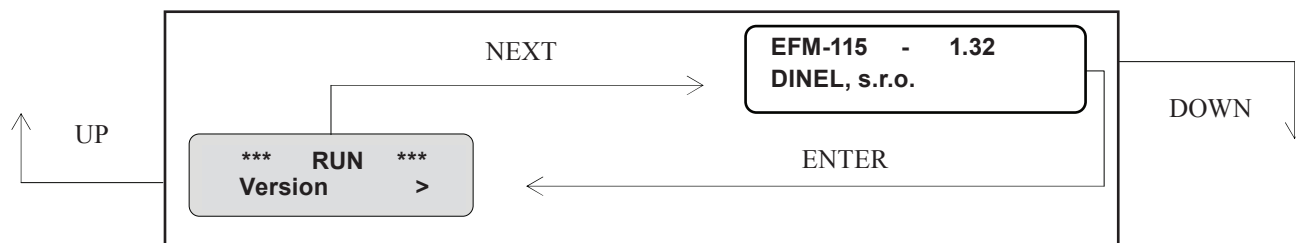

**Run** - moving to the measurement mode and return:



**Run /s** - the measurement process in the service mode:

This is intended for installing and testing the device. The measurement process is launched in the service mode by pressing the NEXT key. The proper measurement runs in the same way as in the user mode, however the method of displaying the quantities on the screen is modified according to service control. Eight screens can be scrolled on the display by pressing the NEXT key.

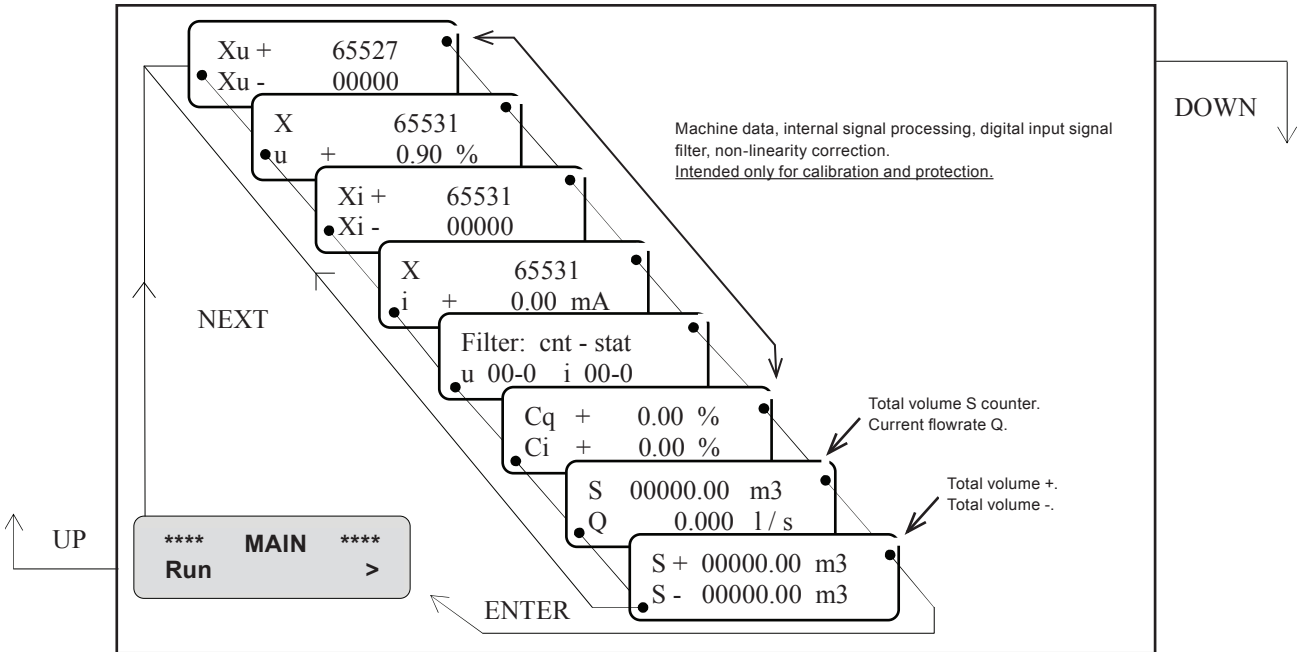

**Qsupp, ..** - low flow rejection limit, identification of positive flow direction, measurement delay after starting the flowmeter:

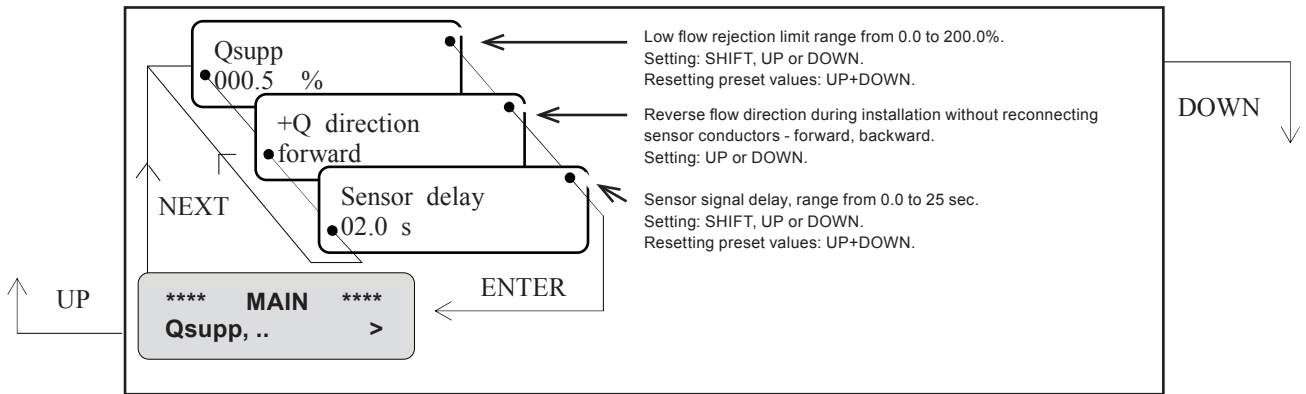

**Filter** - filtration constant and filter delay:

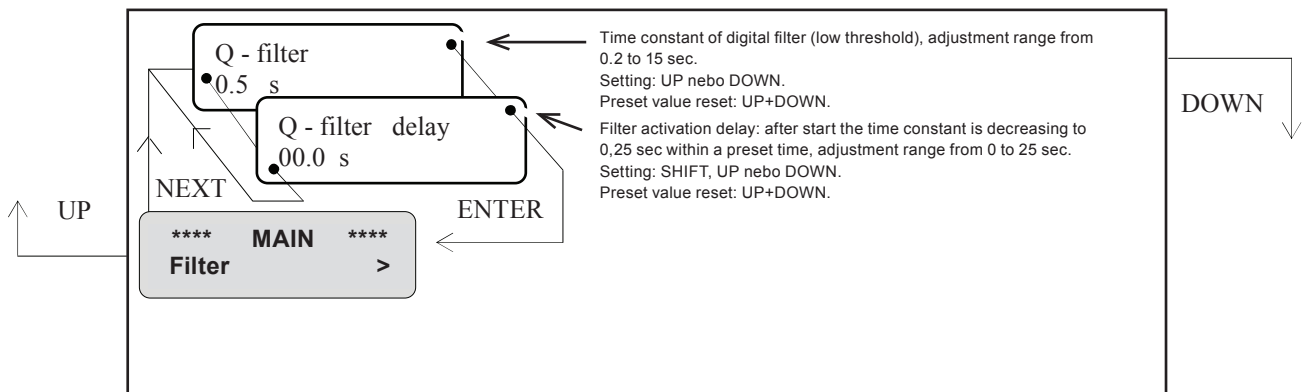

**Range** - current flowrate range: *however the instrument operates up to 200% of this value!*

**Read only parameter.**

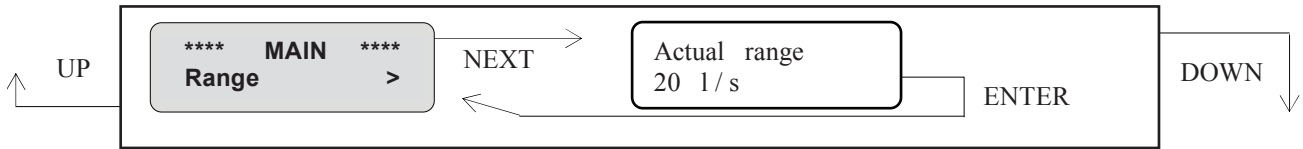

**Display** - time parameters displaying individual quantities, format of displaying individual quantities:

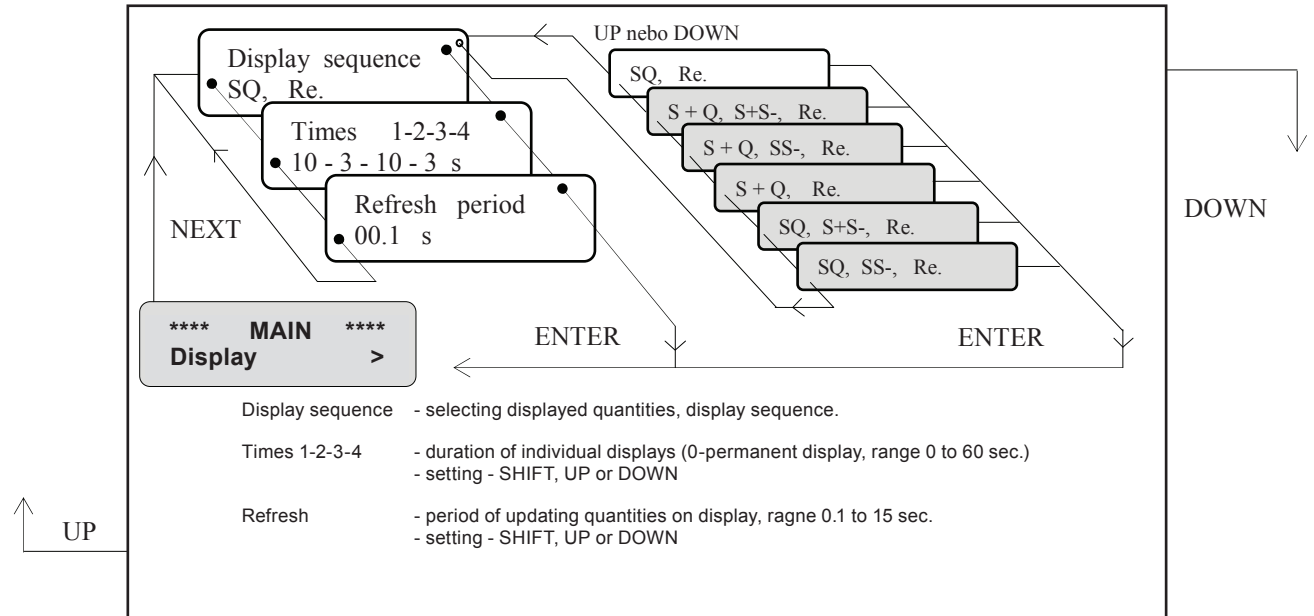

**Unit, format** - flowrate unit Q and format of displaying quantities Q, S+, S-:

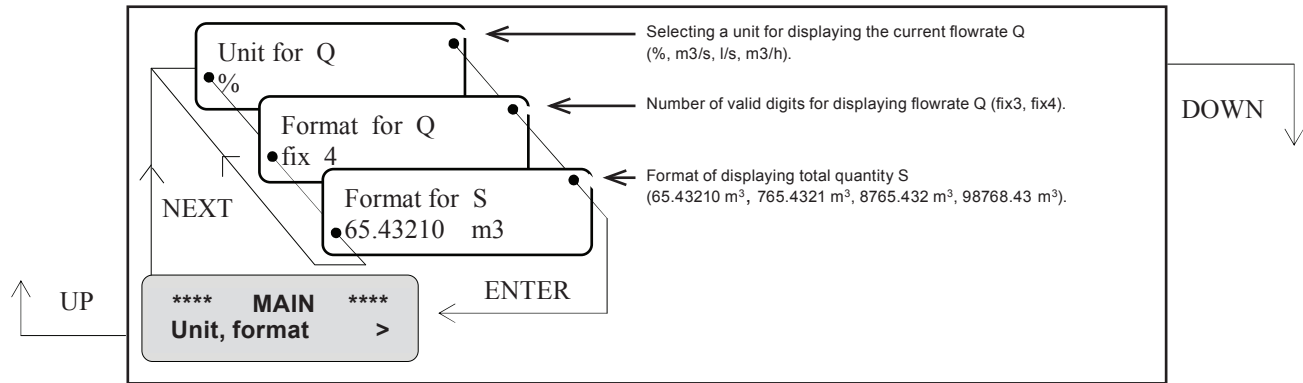

**Pulse output** - pulse output for external counter, total quantity per 1 pulse, pulse width:

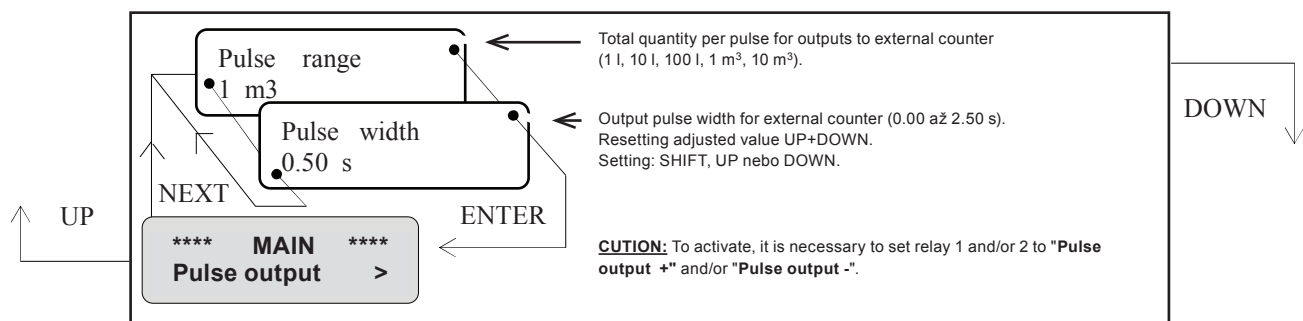

**Comparators** - four flow comparators with 4 modes, static and/or pulse modes are available:

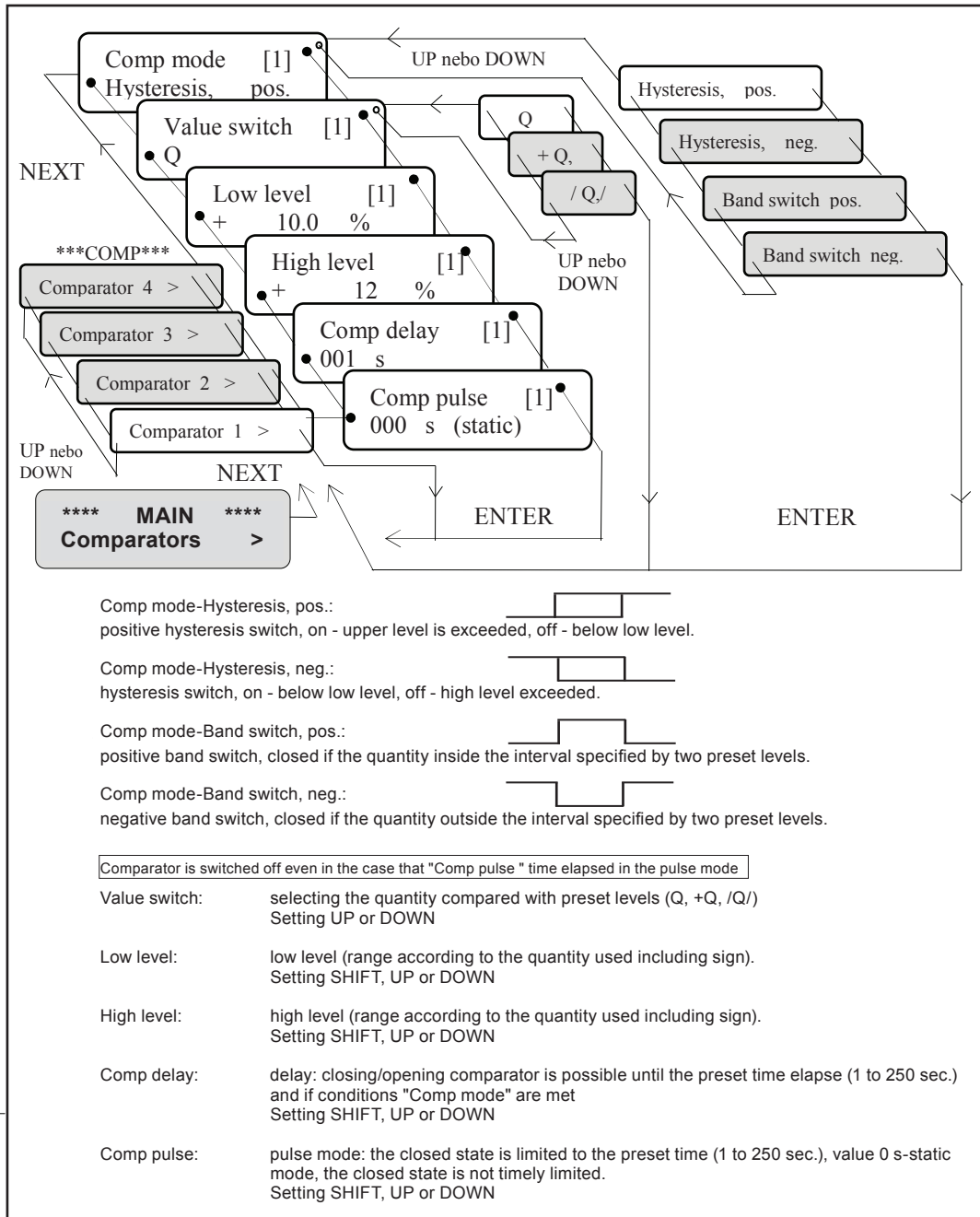

**CAUTION:** In addition to setting the quantities in compliance with the above-mentioned table, it is necessary to select a relay in "Comparators 1 to 4" mode. Otherwise the comparator has no effect on EFM outputs.

**Failure** - intended for a future parameter extension that will control the status:

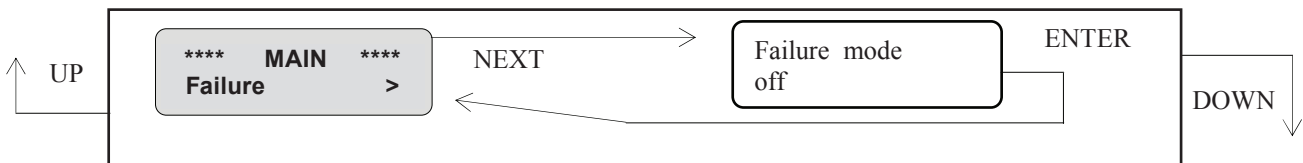



**RS 485 - entering transmission line parameters:**

The communication line makes it possible to transfer not only all basic device quantities (Q, S, S+, S- ), but also all statistic records. This output is programmed to the transmission format. This is a binary asynchronous protocol which is written by the manufacturer's company. Protocol for EFM-115 documentation is not shipped commonly.

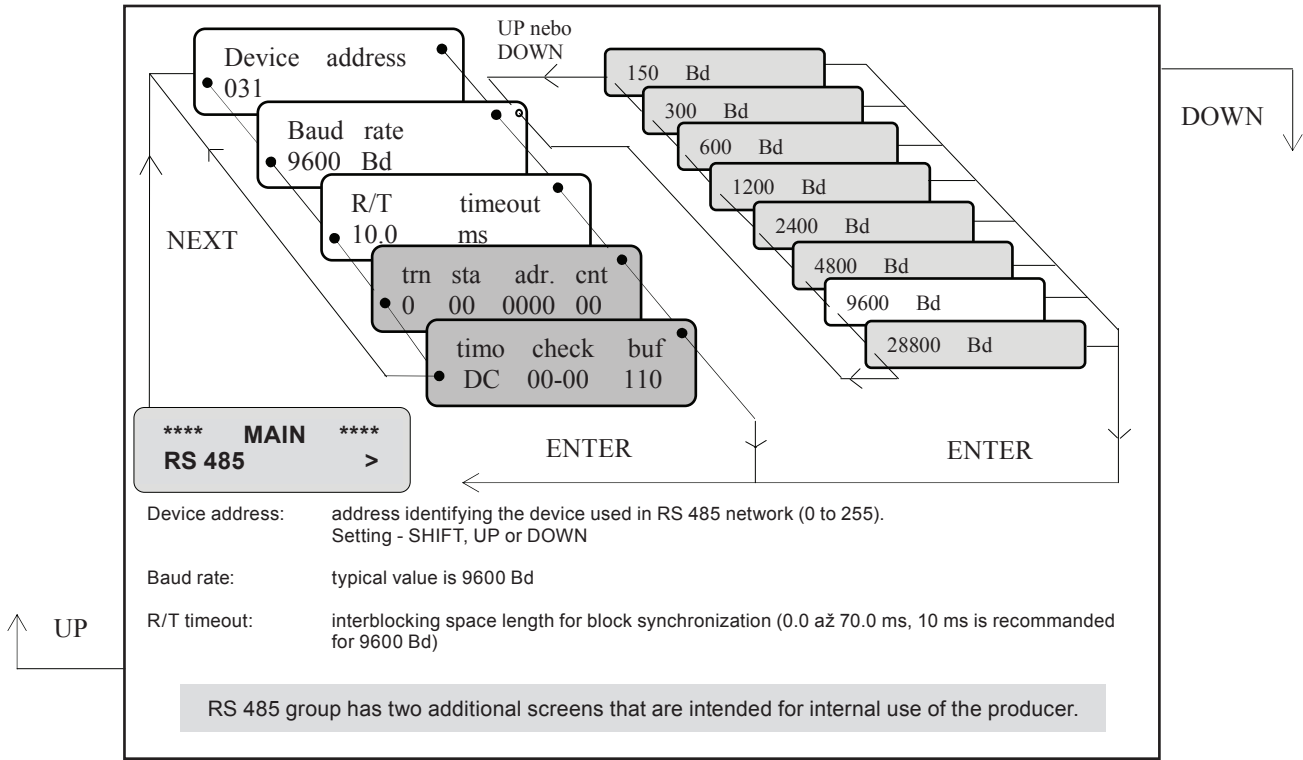

**Manual output- manual control (testing) of 1 to 4 relays, and current and frequency output:**

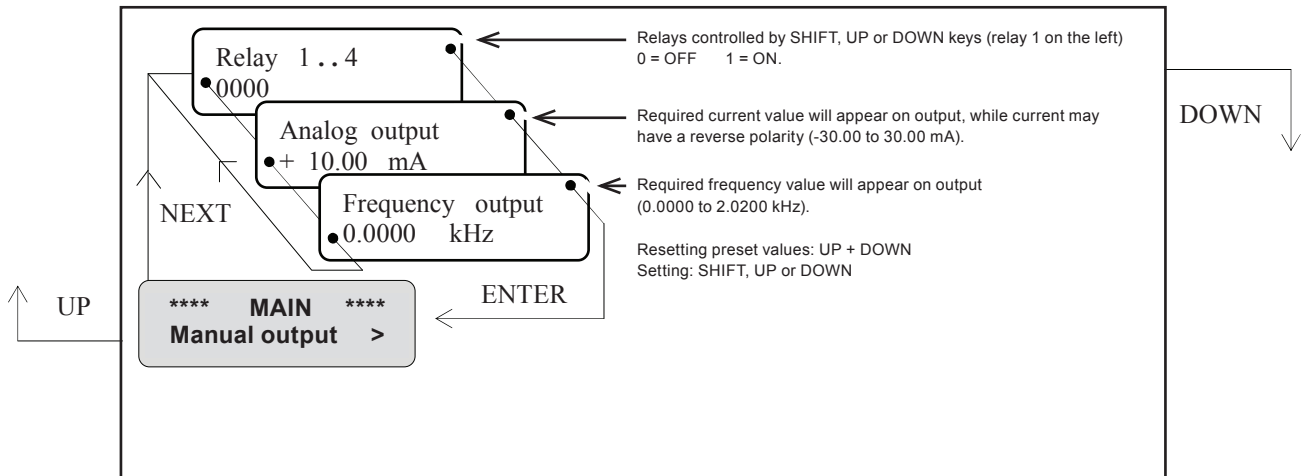

**Zero adjust**- setting the zero point of the device, performance during calibration in factory, any readjustment during installation is possible:

Consult the manufacturer if you want to change zero adjust. The adjustment is given by the quantity value Zu (%) that can be measured or set from the keyboard.

**Legend to the following graphics:**

- \* Press NEXT key in the case that the Zu value should be measured, otherwise use ENTER or ESCAPE to return to menu.
- \*\* The measurement is completed automatically when the preset number of samples (limit) has been measured (this number of samples is optimised in the factory). Only in an emergency, should pressing NEXT or ESCAPE key from the keyboard be used to interrupt the measurement.

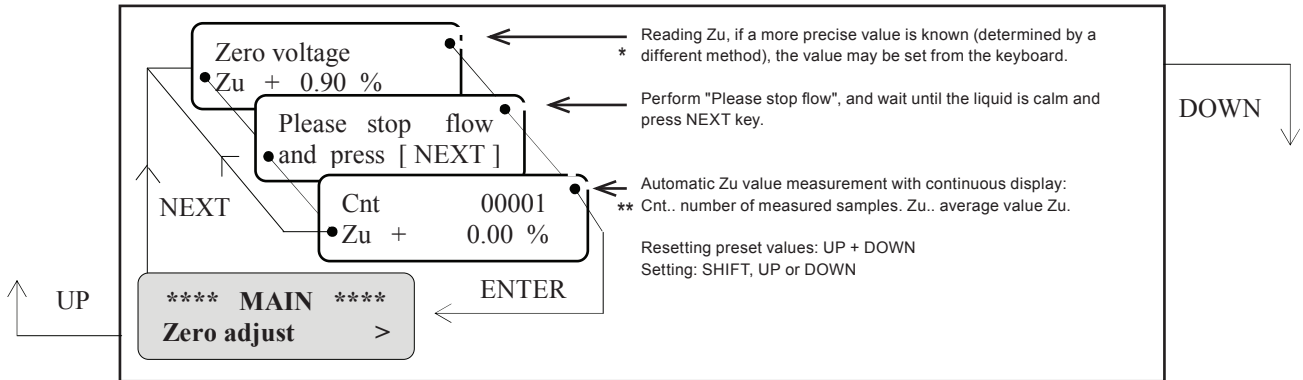

**Recalibration** - setting parameters of automatic internal recalibration in the measurement mode:

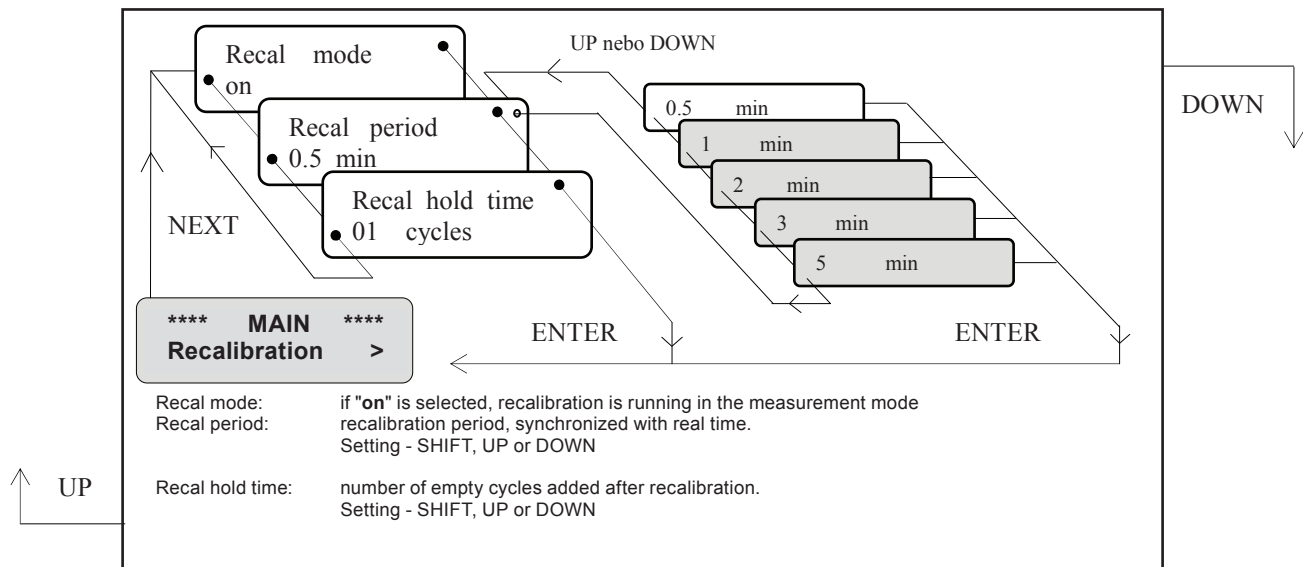

**Air detector - setting parameters for empty pipe detection:**

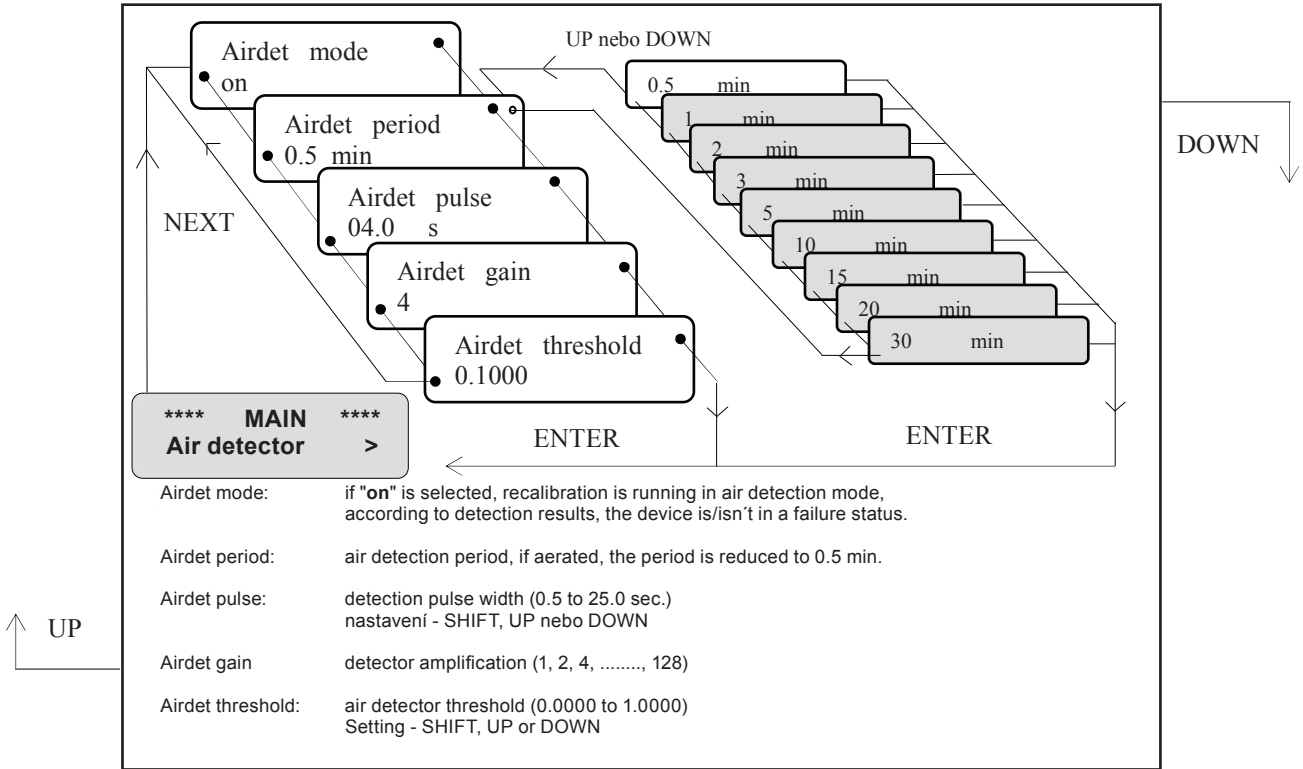

**Cleaner - circuits for electrodes cleaning are not included in this version of firmware.**

**Parameter "Cleaner mode" must remain in state "off".**

**Date, time - setting the date and time**

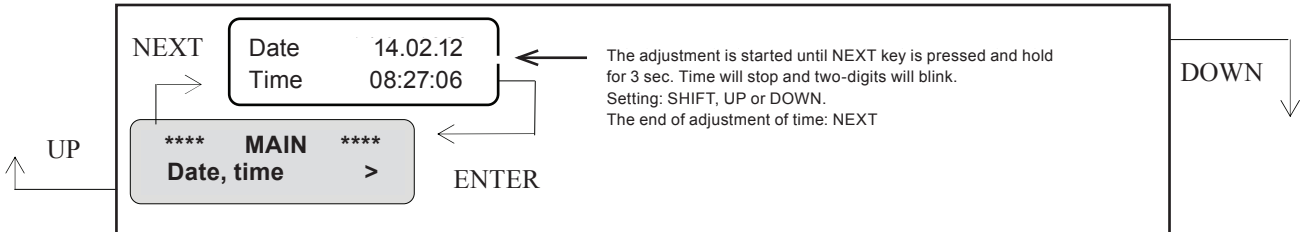

**Password - setting access password:**

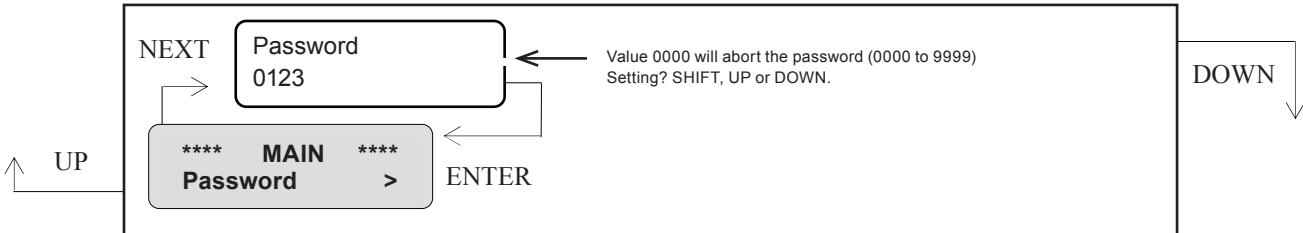

**Version - device type and program version:**

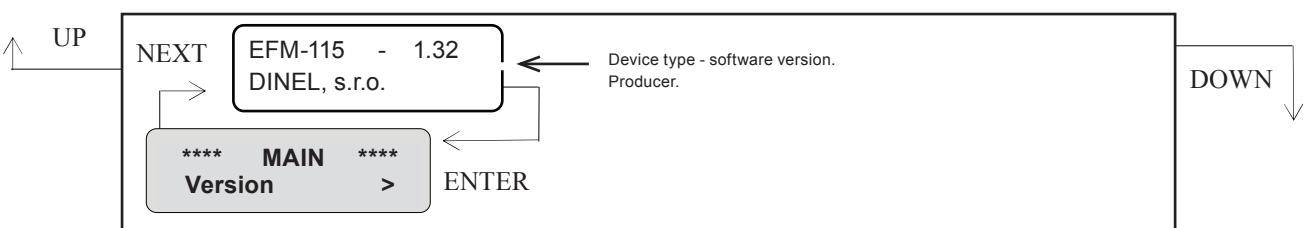



## 9. FLOWMETER ASSEMBLY AND APPLICATION

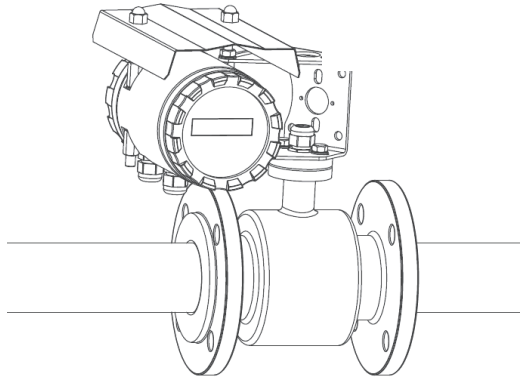

Flowmeter assembly in horizontal pipe

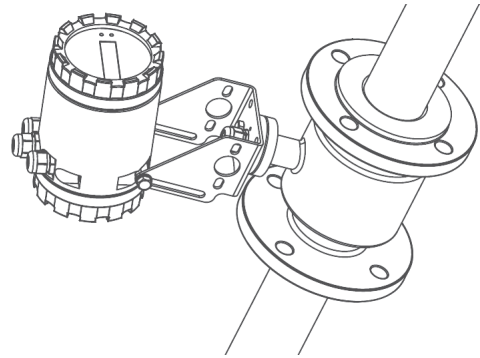

Flowmeter assembly in upward pipe

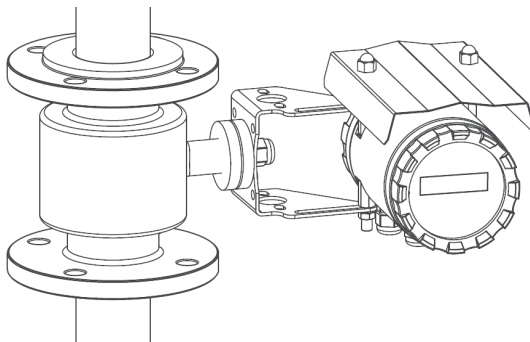

Flowmeter assembly in vertical pipe

## 10. ORDER CODE

EFM-115-DN  -R  -  -  V

Nominal size:  
15; 20; 25; 32; 40; 50;  
65; 80; 100; 125; 150; 200

Supply voltage: **230** – 85...260 VAC/50 ... 60Hz  
**24** – 9...36VDC  
Communication: **0** – without communication  
**M** – RS 485 / Modbus RTU  
Binary output: **1** – 1 Relay (250V AC; 30V DC/3A)  
**2** – 2 Relay (250V AC; 30V DC/3A)  
**3** – 3 Relay (250V AC; 30V DC/3A)  
**4** – 4 Relay (250V AC; 30V DC/3A)

## 11. EXAMPLES OF CORRECT CODE

EFM-115-DN40-R3-0-230V

(DN40) Nominal size 40 mm; (R3) Binary output 3 pcs of Relay; (0) standard version without communication;  
(230) Supply voltage 85...260 VAC.

EFM-115-DN125-R1-M-24V

(DN115) Nominal size 125 mm; (R1) Binary output 3 pcs of Relay; (M) communication RS 485 / Modbus RTU;  
(24) Supply voltage 9...36VDC.

## 12. SAFETY, PROTECTION AND COMPATIBILITY

Electrical safety according to EN 61010-1.

Electromagnetic compatibility is provided by conformity with standards EN 61326-1 and EN 61000-4-2, -3, -4, -5, -6, -8, -11.

## 13. USE, MANIPULATION AND MAINTANCE

The level meter does not require any personnel for its operation. Follow-up displaying device is used to inform the technological entity operating personnel on the measured substance during the operation.

Maintenance of this equipment consists in verification of integrity of the flowmeter and of the supply cable. Depending on the character of the substance measured, we recommend to verify at least once per year the clarity of measuring electrodes and to clean it. In case any visible defects are discovered, the manufacturer or reseller of this equipment must be contacted immediately.



It is forbidden to perform any modifications or interventions into the EFM-115 flowmeter without manufacturer's approval. Potential repairs must be carried out by the manufacturer or by a manufacturer authorized service organization only.

Installation, commissioning, operation and maintenance of the EFM-115 flowmeter has to be carried out in accordance with this instruction manual; the provisions of regulations in force regarding the installation of electrical equipment have to be adhered to.

## 14. MARKING OF LABELS

### Flowmeters label data EFM-115

Symbol of producer: Dinel logo®  
Internet address: [www.dinel.cz](http://www.dinel.cz)  
Flowmeter type: EFM-115-DNxx-Rx-x-230V, EFM-115-DNxx-Rx-x-24V  
Serial number: Ser. No.: xxxxx – (from the left: production year, serial production No.)  
Pressure range:  $P = 1,6 \text{ MPa}$   
Ambient temperature range:  $t_a = -20 \dots +50 \text{ }^\circ\text{C}$   
Liner material: Hard rubber  
Material of electrodes: Stainless steel 316Ti  
Protection class: IP67  
Compliance mark:   
Electro-waste take-back system mark:   
Arrow shows the direction recommended by the fluid flow



### Flowmeters label data EFM-115

Symbol of producer: Dinel logo®  
Internet address: [www.dinel.cz](http://www.dinel.cz)  
Flowmeter type: EFM-115-DNxx-Rx-x-230V, EFM-115-DNxx-Rx-x-24V  
Serial number: Ser. No.: xxxxx – (from the left: production year, serial production No.)  
Supply voltage:  $U = 85 \dots 260 \text{ V AC} / 50 \dots 60 \text{ Hz}$ ,  $U = 9 \dots 36 \text{ V DC}$   
Consumption:  $P = 10 \text{ VA}$   
Maximal flowrate range:  $Q_{\text{max}} = 20 \text{ m}^3/\text{h}$   
Current output:  $I_{\text{OUT}} = 4 \dots 20 \text{ mA}$   
Impuls output (Relay 1):  $F_{\text{OUT}} = 0,1 \text{ m}^3/\text{impuls}$   
Protection class: IP67  
Compliance mark:   
Electro-waste take-back system mark:



## 15. SPECIFICATION

TECHNICAL DATA – SENSOR	
Nominal size	DN 15 ... 200 mm
Flange type	DIN 2576–PN–16
Connecting cable	Standard 0,5 m / 2 x 2 x 0,25 mm <sup>2</sup>
Coils excitation	Pulse DC
Isolation class of coils excitation	E
Process connection	Flanged DIN
Maximum pressure	1,6 MPa
Protection class	IP67
Liner material / Temperature	Hard rubber / - 5°C ... +90°C
Electrodes material	Stainless steel 316Ti
Outer casing flanges / Flow tube material	Carbon steel standard / Stainless steel 321
External coating	Acrymetal multi component lacquer
Ambient temperature range	-20°C ... +50°C

TECHNICAL DATA – CONTROL UNIT	
Medium electrical conductivity	> 5 µS/cm, for demineralized water > 20 µS/cm
Electrode impedance input	> 10 <sup>10</sup> Ω
Flowrate	Min. 0,3 m/s; Max. 12 m/s
Measurement accuracy	0,3% of reading, while flow is within 10 ...100% of range
Flow filter	Multi-mode adjustment
Low flow rejection	Adjustable in steps 0,1%
Flow direction	Bi-directional measurement is distinguished by sign
Zero flow	Automatic zero point setting
Data logger	4 months capacity (average 5 min. current flowrates)
Display / Resolution	Alphanumeric OLED / 2 x 16 charecters, with backlight
Analog output – Active galvanically separated	4(0) ... 20 mA / 500 Ω
Frequency output – Passive galvanically separated	0 ... 1 kHz
Binary outputs	1 to 4 Relays, non-voltage contact, non-inductive load, 250V AC (30V DC)/3A
Communication outputs	RS-485 / Modbus RTU, galvanically separated
Cable outlets	3x PG 11, Power supply cable Max. 3x 1,5 mm <sup>2</sup>
Power supply	85 ... 260 V AC/50 ... 60 Hz; 9 ... 36 V DC
Power consumption	10 VA
Fuse (internal)	630 mA
Protection class	IP 67
Ambient temperature range	-20° C ... +50°C
Weight	2,6 kg
Housing material	Aluminium alloy
External coating	Powder coating

# **Dinel**<sup>®</sup>

industrial electronics

**Dinel, s.r.o.**

U Tescomy 249  
760 01 Zlín  
Czech Republic

Tel.: +420 577 002 003  
Fax: +420 577 002 007  
E-mail: [sale@dinel.cz](mailto:sale@dinel.cz)

**[www.dinel.cz](http://www.dinel.cz)**

The latest version of this instruction manual can be found at [www.dinel.cz](http://www.dinel.cz)

Version: 03/2013



QMS  
ISO 9001

